



ESPAÑOL

CONTROLADOR DE PROCESOS con WEBSERVER y MQTT
MANUAL TÉCNICO

FRANÇAIS

AFFICHEUR DE PROCESS avec WEBSERVER et MQTT
MANUEL UTILISATEUR

ENGLISH

DPM for PROCESS CONTROL with WEBSERVER and MQTT
USER MANUAL 2/60



INDEX

MICRAMAX OVERVIEW	3
MAINTENANCE	4
WARRANTY	4
INSTRUCTIONS FOR THE RECYCLING	4
GETING STARTED	5
DIMENSIONS AND MOUNTING	5
WEB SERVER.....	6
INPUT CONFIGURATION by WEB SERVER.....	7
DISPLAY CONFIGURATION by WEB SERVER	8
SETPOINT CONFIGURATION by WEB SERVER.....	9
COMMUNICATIONS CONFIGURATION by WEB SERVER	10
DITEL CONNECT APP.....	11
API REST MICRAMAX.....	12/13
MQTT (Exploring the Essencial for IoT Communication)	14/15
MQTT CONFIGURATION by WEB SERVER	16
MQTT SET UP.....	17
MQTT BILLING INFORMATION and PAYMENT METHODE	18
MQTT PURCHASE DATA PLAN	19
MQTT INVOICE HISTORY.....	20
MQTT MAKE A PAYMENT	20
MQTT DATA ACCES	21
ANALOG OUTPUT CONFIGURATION by WEB SERVER	22
LOGIC FUNCTIONS CONFIGURATION by WEB SERVER.....	23
LOCK OUT PROGRAMMING by WEB SERVER.....	24
FACTORY RESET by WEB SERVER	225
PROGRAMMING MODE by KEYBOARD.....	26
POWER SUPPLY and CONNECTORS	27
INPUT CONFIGURATION by KEYBOARD.....	28/29/30
LOAD CELL INPUT PROGRAMMING by KEYBOARD.....	31
PT100 INPUT PROGRAMMING by KEYBOARD	32
THERMOCOUPLE INPUT PROGRAMMING by KEYBOARD	33
DISPLAY CONFIGURATION by KEYBOARD.....	34/35/36
KEYBOARD FUNCTIONS.....	37/38/39
LOCK OUT PROGRAMMING by KEYBOARD	40/41
OUTPUT OPTIONS.....	42
SETPOINT OPTIONS.....	43/44/45
RS2/RS4 OUTPUT COMMUNICATION OPTIONS	46
ETH OUTPUT COMMUNICATION	47
ASCII / ISO 1745 PROTOCOL	48/49/50
MODBUS RTU COMMANDS and MAP ADRESSES	51/52/53/54/55/56/57
ANALOG OPTION OUTPUT by KEYBOARD	58/59
TECHNICAL SPECIFICATIONS	60

MICRA-M MAX Overview

MICRA-M MAX is a versatile instrument equipped with **Web Server**, **Bluetooth** and **MQTT** capabilities.

It can be configured for various types of inputs:

- **PROCESS Input** : Voltage (V), Current (mA)
- **LOAD CELL Input** : Milivolt (mV)
- **Pt100 Input**
- **THERMOCOUPLE Input** : Types J, K, T, N

Basic Instrument Set:

The basic instrument set includes:

- Motherboard
- Programmable tricolor display
- Power Supply
- **Ethernet communication option.**

Output Options :

Various plug-in output cards can be installed to enhance the system

- **RS232C Serial (RS2)**
- **RS485 Serial (RS4)**
- **ETHERNET (Included in basic model)**

Standard features:

The **MICRA-M MAX** offers a range of standard features:

- Reading of input variables
- Remote HOLD functionality
- Reading and memorization of maximum and minimum values (peak/valley)
- Tare and reset functions
- Comprehensive programmable logic functions

Control Options :

The **MICRA-M MAX** supports multiple control output options:

- **NMA** Analogue 4-20mA
- **NMV** Analogue 0-10V
- **2RE** 2 Relays SPDT 8A
- **4RE** 4 Relays SPST 5A
- **4OP** 4 NPN output
- **4OPP** 4 PNP output

Communication and Configuration :

The **MICRA-M MAX** incorporates several communication and configuration features:

- **Web Server:** Allows initial setup with login and provides instant readings of measured variables
- **Bluetooth :** After downloading the Ditel Connect application, the instrument can be configured via Smartphone
- **MQTT Protocol:** Enables communication with an MQTT Server.
- **REST API :** Facilitates communication and data exchange between different systems.

For detailed information, visit the portal :

micramax.ditel.es

General security

All indications and instructions for installation and handling provided in this manual must be strictly followed to ensure personal safety and prevent damage to this equipment or any connected equipment.

The safety of any system incorporating this equipment is the responsibility of the system assembler.

If the equipment is used in a manner different from that specified by the manufacturer in this manual, the protection provided by the equipment may be compromised.

Symbol identification



ATTENTION: Possibility of danger.

Read the related instructions completely when this symbol appears in order to know the nature of the potential danger and the actions to take to avoid it.



ATTENTION: Possibility of electric shock



Equipment protected by double insulation or reinforced insulation

MAINTENANCE

To ensure the precision of the instrument, it is advisable to verify its compliance with the technical specifications contained in this manual. Regular calibrations should be performed at intervals determined by the specific usage criteria of each application.

Calibration or adjustment of the instrument must be conducted by an Accredited Laboratory or directly by the Manufacturer.

Repairs should only be undertaken by the Manufacturer or authorized personnel.

To clean the front of the equipment, gently rub it with a cloth soaked in neutral soapy water.
DO NOT USE SOLVENTS!

WARRANTY



The instruments are warranted against defective materials and workmanship for a period of FIVE years from date of delivery.

If a product appears to have a defect or fails during the normal use within the warranty period, please contact the distributor from whom you purchased the product.

This warranty does not apply to defects resulting from the buyer's action such as mishandling or improper interfacing.

Liability under this warranty is limited to repair of the instrument. The manufacturer assumes no responsibility for any damage that may result from the use of the instrument.

INSTRUCTIONS FOR THE RECYCLING



This electronic instrument is covered by the **2002/96/CE** European Directive so, it is properly marked with the crossed-out wheeled bin symbol that makes reference to the selective collection for electrical and electronic equipment which indicates that at the end of its lifetime, the final user cannot dispose of it as unsorted municipal waste.

In order to protect the environment and in agreement with the European legislation regarding waste of electrical and electronic equipments from products put on the market after 13 August 2005, the user can give it back, without any cost, to the place where it was acquired to proceed to its controlled treatment and recycling.

GETTING STARTED

Packing contents

- Quick start of panel meter
- Digital panel meter **MICRA-M MAX**.
- Accessories for panel mounting (sealing gasket and fixing clips).
- Accessories for wiring connections (plug-in terminal block connectors with a fingertip key).
- Wiring label stuck to the **MICRA-M MAX** case.
- 4 set of labels with engineering units and **Coupon Code** for MQTT Free Plan.

Programming instructions

The instrument has software that, through its keyboard, allows access to independent programming menus to configure the input, display and logical functions. If additional options are installed (communications outputs, analog output and relay output), once recognized by the instrument, they activate their own programming software.

Programming can also be done through a PC using the built-in **web server** and the configuration API, or through **Bluetooth** for Smartphone with the DITEL Connect APP that can be downloaded from our portal micramax.ditel.es

Programming lock-out

Total or selective lock-out of programmed parameters can be done via **web server** or local keyboard.

The instrument is delivered from factory with unlocked programming, e.g., with all the programming levels accessible to the operator

The figure below shows the locations of the different output options available.

DIMENSIONS and MOUNTING

The figure below shows the locations of the different output options available.

The **2RE, 4RE, 4OP** y **4OPP** options are alternative and only one of them can be installed in the M1 connector.

The **RS2, RS4** and **ETH** options are also alternative and only one of them can be installed in the M2 connector.

The **NMA** or **NMV** are also alternative and only one of them can be installed in the M3 connector.

Up to three output options can be installed and operate simultaneously:

- 4-20mA or 0-10V (only one)
- RS232C, RS485 or ETH (only one)
- 2 RELAYS, 4 RELAYS o 4 OPTO (only one).

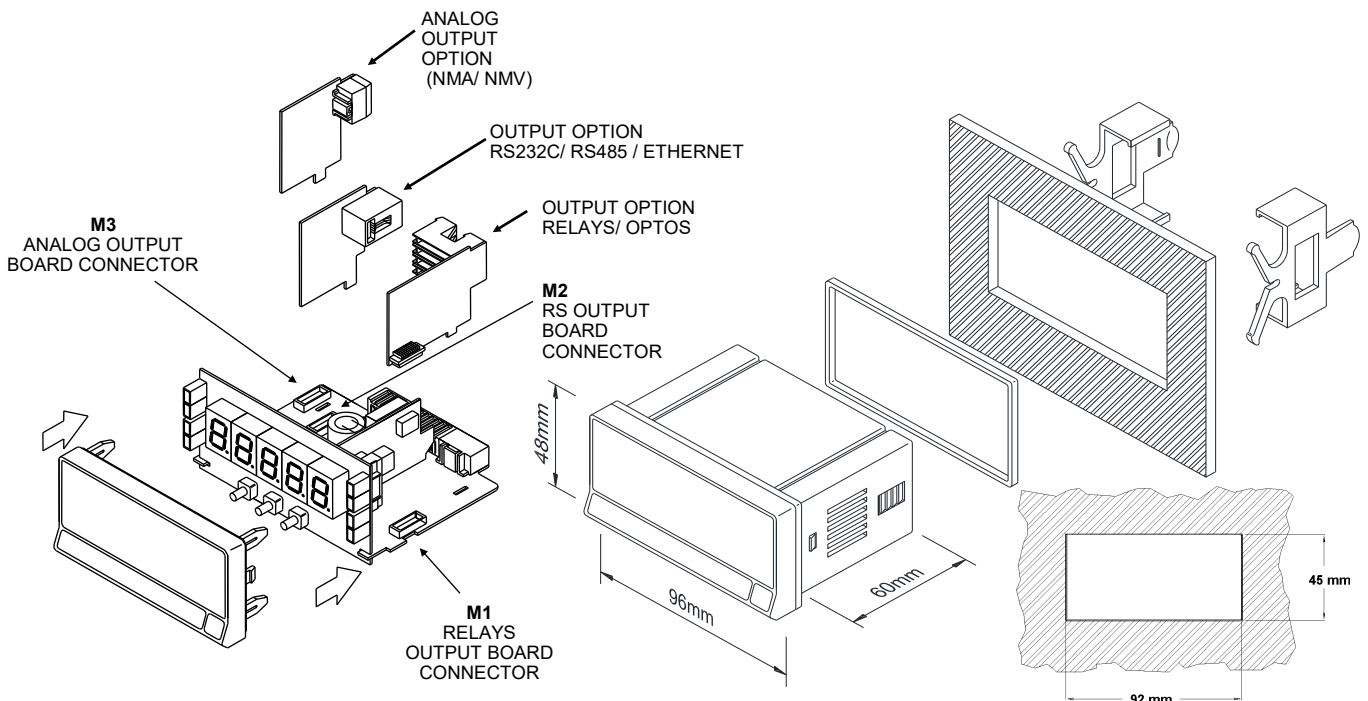

WEB SERVER

INITIAL SETUP AND LOGIN

To connect to the Micra Max web server, it is necessary to have the device physically in front of you to enter the **Micra MAX** setup using the device's buttons. Once there, configure the service IP (see pag. 47). This service IP is what will allow you to connect to the web server through a browser by simply composing the URL with :

"http://" followed by the IP address.

Before you can begin configuring your Micra-M MAX device via webserver, you must log in to the software using your account credentials.

This ensures secure access to your device settings and configurations.

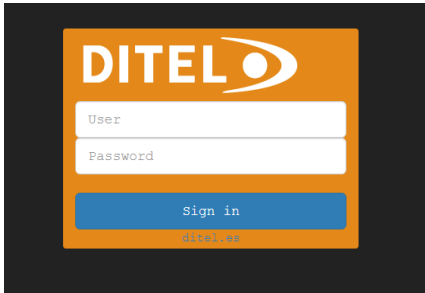

If you encounter any issues during the login process, or if you have forgotten your password, please contact support at ditel.es for assistance.

Accessing the Login Screen:

When launching the Micra-M MAX webserver, you'll be directed to the login screen.

Entering Your Credentials:

Enter your log and password in the designated fields. **admin/admin** are the default credentials. These credentials can be modified when you log in the webserver.

Sign In:

After entering your credentials, click the "Sign in" button to access the software dashboard. If your login details are correct, you'll be taken to the main dashboard where you can start configuring your device via webserver.

INSTANT MEASURES

The "Instant Measures" feature of the Micra-M MAX software provides real-time data on various measurement parameters. This section of the manual explains how to view and reset these measurements.

Viewing Measures

Upon navigating to the "Measures" section from the main dashboard, you'll be presented with a comprehensive overview of the current measurement parameters:

Minimum:

Displays the minimum value recorded for the selected measurement period.

Maximum:

Shows the maximum value recorded for the same period.

Setpoint 1 - 4:

Indicates the current values set for each of the four setpoints.

These measurements are dynamically updated, providing instant feedback on the system's performance.

Display

The central display area shows the primary measurement in a large, easy-to-read format. This is the current value measured by the system.

Commands

Adjacent to the display, a series of commands allow for direct interaction with the measurement system:

Reset Min: Resets the minimum value to begin recording from the current measurement onwards.

Reset Max: Resets the maximum value to begin recording from the current measurement onwards.

Tare: Adjusts the measurement base to zero, allowing for differential measurements.

Reset Tare: Returns the measurement base to its original state, removing any tare adjustments.

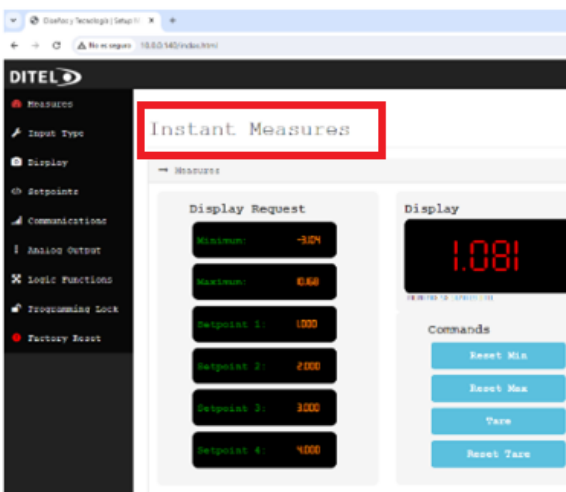

INPUT CONFIGURATION by WEB SERVER

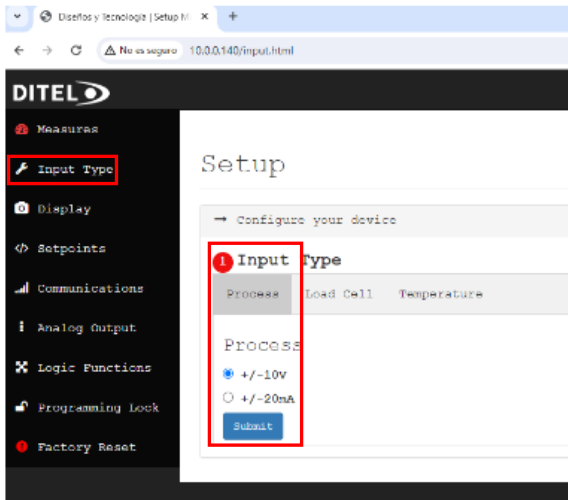

Accessing Input Type Configuration

To configure the input type:

Navigate to the "Input Type" section from the main dashboard.

You will see three main input categories: Process, Load Cell, and Temperature.

Each category is designed to match specific measurement types and scenarios.

Process Input Configuration

Select "Process" if you are measuring standard process signals. In this mode, you can choose between:

±10V: For voltage signals ranging from :
-10V to +10V.

±20mA: For current signals ranging from :
-20mA to +20mA.

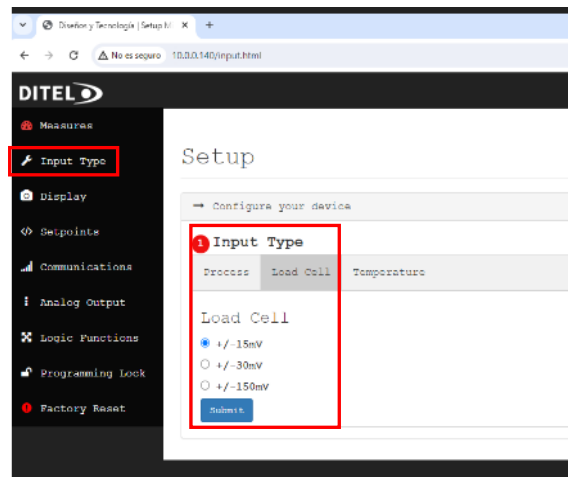

Load Cell Input Configuration

For measuring weight or force via load cells, select "Load Cell" and configure as follows:

±15mV: Suitable for low voltage load cell signals.

±30mV: For slightly higher voltage requirements.

±150mV: For load cells with higher voltage output.

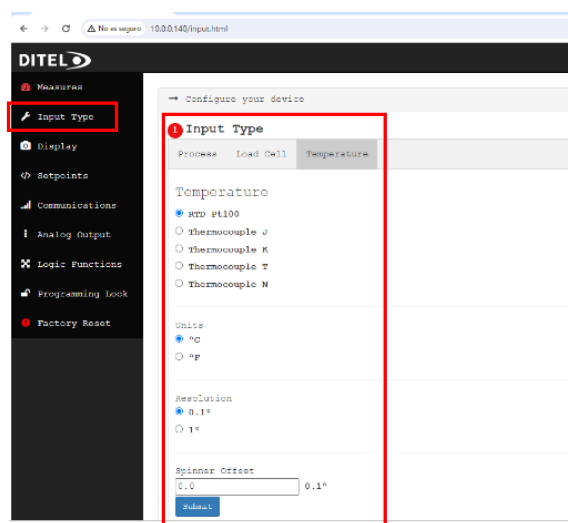

Temperature Input Configuration

To measure temperature, choose "Temperature" and specify the sensor type:

RTD Pt100: For resistance temperature detectors with Pt100 sensors.

Thermocouple J, K, T, or N: Depending on the thermocouple type you're using.

Additionally, you can set:

Units: Choose between Celsius (°C) and Fahrenheit (°F).

Resolution: Select the measurement resolution (0.1° for finer measurements or 1° for broader readings).

Spinner Offset: Adjust the baseline offset for calibration purposes.

Submitting Your Configuration

After selecting your desired settings within any of the input type tabs, click the "Submit" button to apply your configuration. This action will tailor the **Micra-M MAX** software to accurately interpret signals from your specific input type.

DISPLAY CONFIGURATION by WEB SERVER

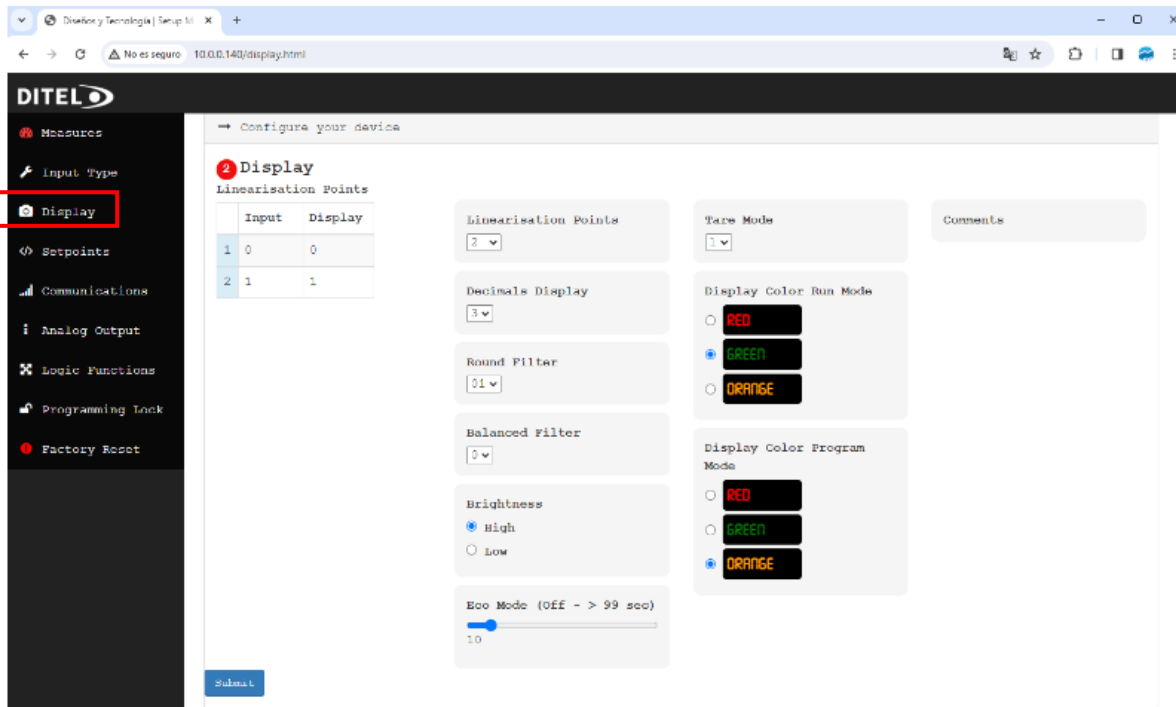

ENGLISH

The Display Settings in the **Micra-M MAX** software allow for detailed customization of how data is shown on your device, enhancing user interaction based on the specific needs of your application. This section covers how to adjust these settings for the best user experience.

Accessing Display Configuration

To modify the display settings:
From the main dashboard, navigate to the "Display" section.

You will encounter a variety of options that can be customized, including Linearisation Points, Decimals Display, and more.

Linearisation Points

The software supports the adjustment of linearisation points to fine-tune the relationship between the input signal and displayed value:

Adding Points: You can specify up to 11 linearisation points. Each point allows for the input value to be mapped to a specific display value, enabling precise calibration for nonlinear sensors.

Configuring Points: Enter the desired Input and Display values for each point directly in the provided table.

Display Options

Decimals Display: Choose how many decimal places are shown for measurement values, enhancing precision or simplifying the readout as needed.

Round Filter: Select a rounding filter to apply to the display values, smoothing out minor fluctuations for easier reading.

Balanced Filter: Adjust the balance between responsiveness and stability in the displayed readings with options ranging from 0 (most responsive) to 9 (most stable).

Brightness: Set the display brightness to High or Low, accommodating different lighting conditions.

Eco Mode: Activate Eco Mode to reduce power consumption by dimming the display after a specified time of inactivity (0 to 99 seconds).

Color Configuration and Modes

Customize the display color to distinguish between different operational modes:

Display Color Run Mode: Choose between Red, Green, and Orange for the normal operating mode.

Display Color Program Mode: Similarly, select a color that will be used when the device is in programming mode, aiding in clear mode differentiation.

Additional Settings

Tare Mode: Configure how the tare function behaves, with options to reset to zero under different conditions.

Submitting Your Configuration

Once you've made your selections:
Review all settings to ensure they meet your requirements.

Click the "Submit" button to apply your changes, which will immediately take effect.

SETPOINT CONFIGURATION by WEB SERVER

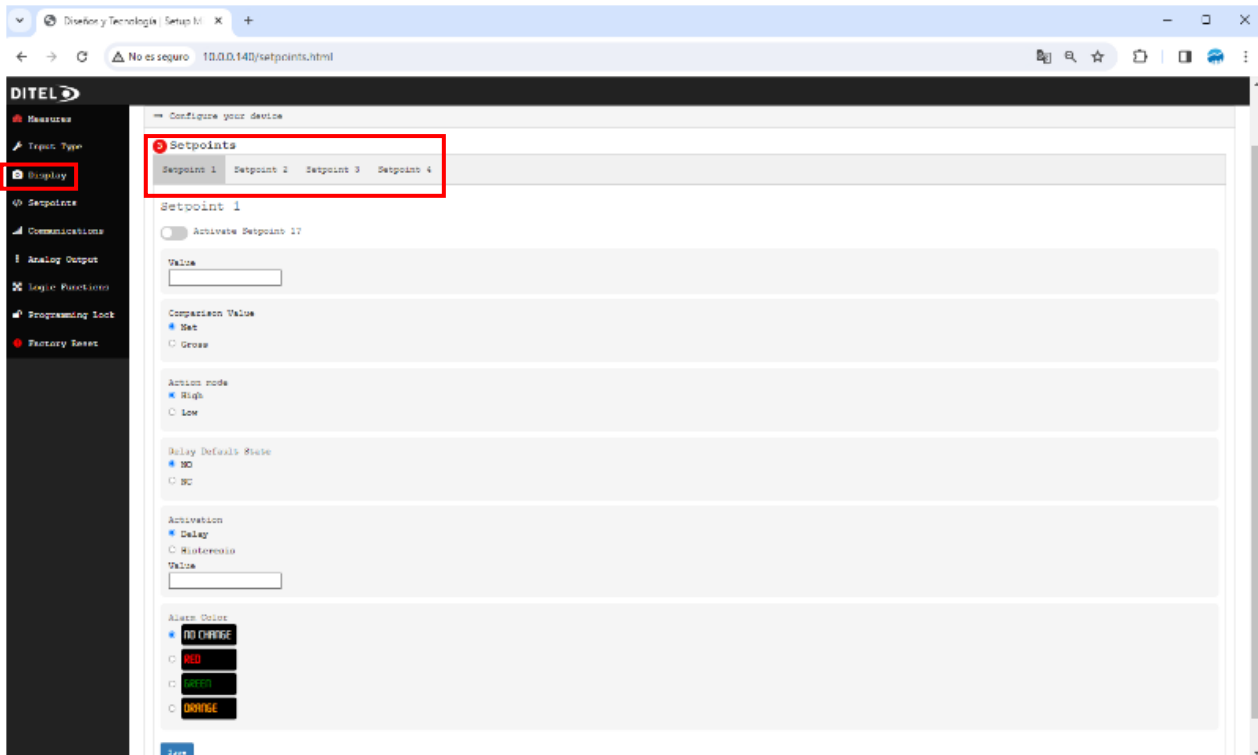

ENGLISH

The **Micra-M MAX** software allows the configuration of up to four setpoints, providing flexibility in how the device reacts under specific conditions. This section explains how to set up and customize each setpoint

Accessing Setpoint Configuration

To begin setting up your setpoints:

Navigate to the "Setpoints" section from the main dashboard.

You will see options to configure each of the four setpoints individually.

Setpoint Configuration Details

Each setpoint tab allows you to configure the following parameters:

Activation: Toggle to enable or disable each setpoint individually.

Value: Set the trigger value for the setpoint. This is the measurement threshold that activates the setpoint's action.

Comparison Value: Choose between "Net" and "Gross" values for comparison against the setpoint value.

Action Mode: Select "High" if the setpoint action should occur when the measurement is above the set value, or "Low" for below.

Relay Default State: Determine the default state of the relay as "Normally Open" (NO) or "Normally Closed" (NC).

Activation: Specify the activation condition as either "Delay" for a timed response or "Hysteresis" to prevent oscillation around the setpoint value.

Value: Define the delay time or hysteresis margin, respectively.

Alarm Color: Choose the color displayed when the setpoint is active. Options include "No Change", "Red", "Green", or "Orange" to indicate different states or alarms.

Submitting Your Configuration

Once you've made your selections: Review all settings to ensure they meet your requirements. Click the "Submit" button to apply your changes, which will immediately take effect.

COMMUNICATIONS CONFIGURATION by WEB SERVER

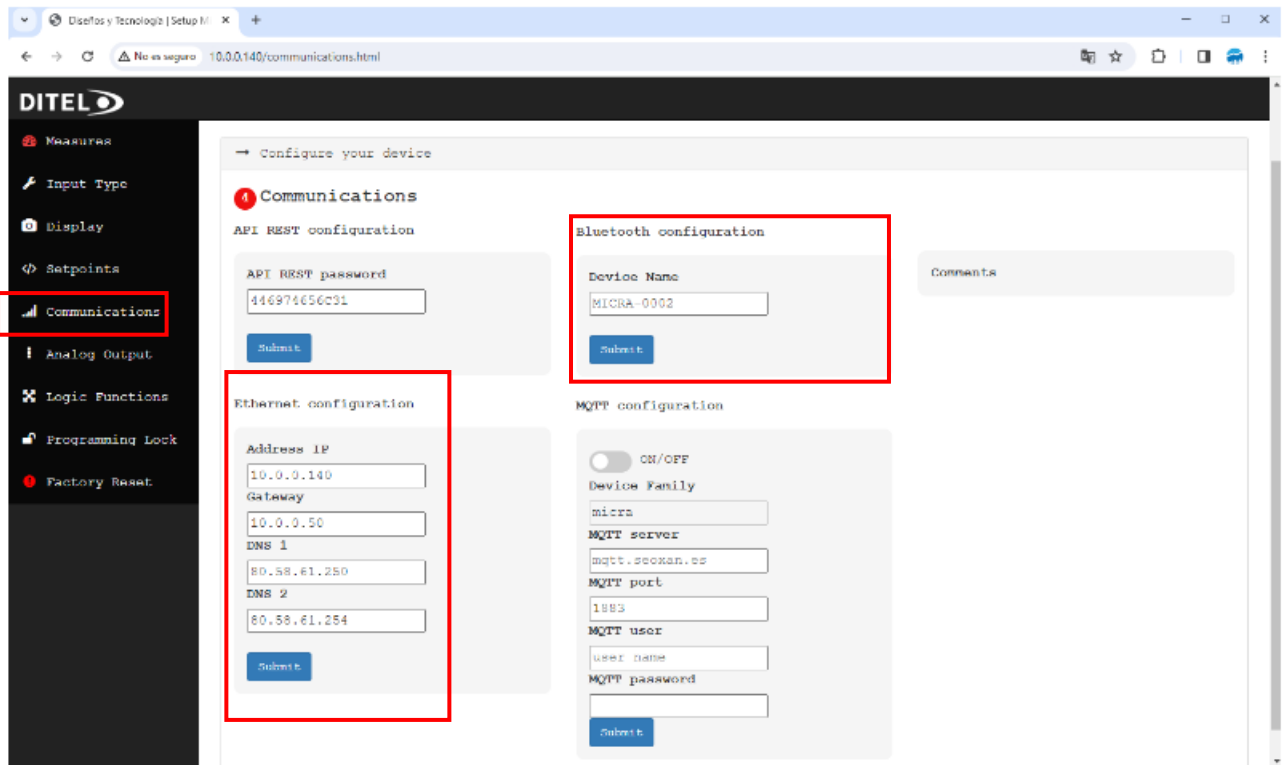

ENGLISH

The **Communications** menu provides the interface for configuring the communications of a specific device, offering options for configuring **Ethernet, Bluetooth, and MQTT**.

Ethernet Configuration

This section allows the user to configure the IP address, the gateway, and the DNS servers for the device's Ethernet connection.

IP Address: Field to enter the device's IP address on the network. It must be a valid address in the format xxx.xxx.xxx.xxx.

Gateway: Field to enter the default gateway for the device's network. It must be a valid address in the format xxx.xxx.xxx.xxx.

DNS 1 and DNS 2: Fields to enter the addresses of the primary and secondary DNS servers. It must be a valid address in the format xxx.xxx.xxx.xxx.

Before saving the configuration, ensure that all addresses are valid and within the allowed range for your network

Bluetooth Configuration

Allows the user to configure the device name. Other configurations must be set on the fisic micra keys.

Device Name: Field to set the name that will be displayed for the Bluetooth device.

Enabling Bluetooth allows wireless connection with other devices.

DITEL CONNECT APP

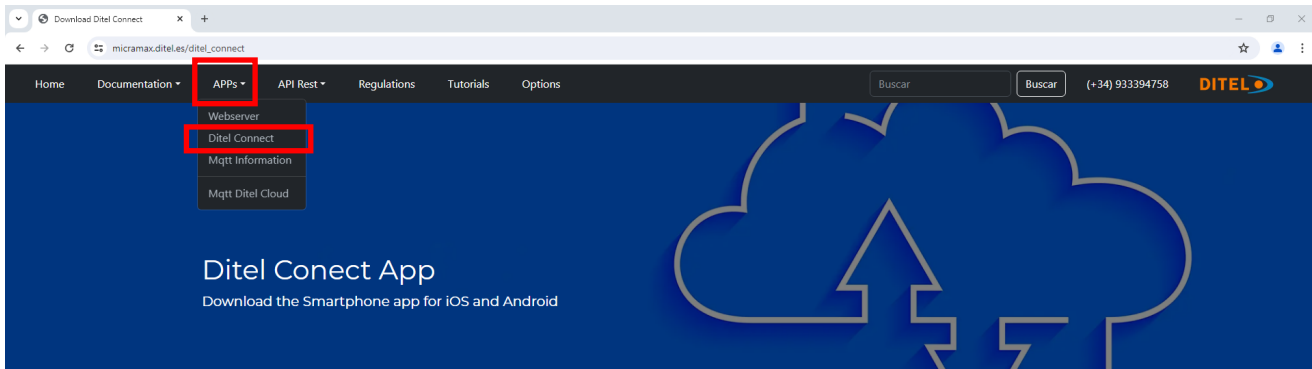

INTRODUCTION

DITEL Connect APP Purpose

The purpose of this APP is to provide a micra max configuration software application for IOS (coming soon) and Android. Find the download links at micramax.ditel.es/ditel_connect

Google Play Juegos Apps Películas Libros Infantiles



DITEL Connect

Diseños y Tecnología, S.A.

10+ Descargas PEGI 3

Instalar

Compartir Agregar a la lista de

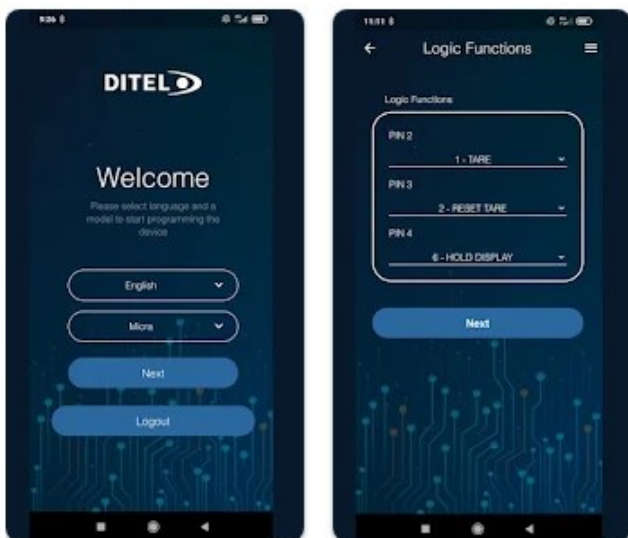

With this application you will be able to easily configure all the required parameters on a digital panel meter from DITEL's KOSMOS series.

- Input type
- Display type
- Fixed point
- Programmable logic functions
- Analog output parameters
- Communication protocol and interface

To pair a Bluetooth device to **MICRA-M MAX**, we have to press the ENTER key, display shows -Pro- and then press for 3 sec the central MAX/MIN key.

A 5-digit number will appear for two minutes that we must use at the time of pairing.

The bluetooth library uses a 6-digit number to pair, so in our case we will have to add a 0 to the left.

Example:

Display **MICRA-M MAX** indicates **47985**, our Code to pair the device will be **047985**.

API REST MICRA MAX

INTRODUCTION

API Purpose

The purpose of this API is to provide a REST application programming interface (API) to facilitate communication and data exchange between different systems. This API has been developed with the objective of allowing developers to access and manipulate certain resources and specific functionalities of our system or application in an efficient and secure manner.

Using this API, developers will be able to integrate and use our functionalities in their own applications, thus taking advantage of the capacity and data of our system in a flexible and personalized way. Additionally, by following REST design principles, our API adheres to widely accepted standards, making it easy to adopt and deploy across diverse environments and platforms.

By providing a **REST API**, our goal is to encourage the creation of applications and services that can effectively interact with our system. This opens new opportunities for collaboration, innovation and the creation of solutions that improve the user experience and provide greater added value through the integration of our functionalities. Throughout this documentation, you will find detailed information about available endpoints, request parameters, response formats, required authentication, and recommended best practices to use our API effectively. We hope this documentation is a useful guide so developers can take full advantage of the capabilities of our API and build powerful and innovative applications.

GOALS AND USE CASES

Provide developers with a standardized interface to access and use data generated by probes and sensors connected to **Micra MAX**.

Facilitate the integration of **Micra MAX** into existing applications and systems, allowing the exchange of information in real time.

Improve visualization efficiency in capturing, analyzing and displaying data collected by **Micra MAX**.

Drive innovation by enabling developers to create custom solutions based on information provided by **Micra MAX**.

USE CASES

Process Monitoring and Control : The API allows developers to obtain real-time data from the probes and sensors connected to **Micra MAX**, which facilitates the monitoring and control of industrial processes, such as temperature, humidity, pressure, among other critical parameters.

Integration into Asset Management Platforms : Data from **Micra MAX** can be used in asset management platforms, allowing users to monitor and manage equipment and systems in real time. For example, the API can be used to receive automatic alerts in case a sensor connected to **Micra MAX** indicates a problem or a value outside the established limits.

Data Analysis and Report Generation : The API makes it easy to extract data stored in **Micra MAX**, allowing developers to perform advanced analysis and generate custom reports. For example, sensor data can be used to identify patterns, trends and anomalies, which can be useful in predictive equipment maintenance or process optimization.

These are just a few examples of the goals and use cases that the **Micra MAX** Connection API can address. By providing an easy-to-use and flexible interface, our API allows developers to take full advantage of the data generated by **Micra MAX**, opening up a world of possibilities for creating customized solutions and improving efficiency across various sectors and applications.

You can find all the informations at micramax.ditel.es

API REST MICRA MAX

AUTHORIZATION

Authorization to access the API is done through a Token, which must be included in the request header with the name "X-DTpanel".

The Token or password necessary for authorization is defined within the **Micra MAX** device **webserver on communications** menu.

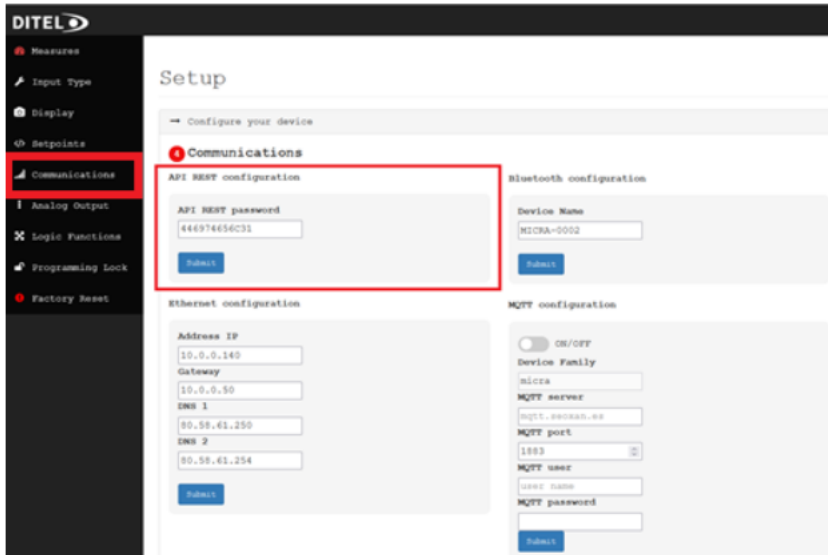

IMPORTANT:

the user has the ability to modify this Token, providing flexibility and control over the security of requests made to the hardware. To ensure effective and secure communication, it is recommended to generate and use a strong and unique Token

COMMUNICATION

Communication with the **Micra MAX** API is done through JSON (*JavaScript Object Notation*) objects. Both requests sent and responses received must be in JSON + UTF-8 format to ensure compatibility and ease of data processing.

APPLICATION METHODS

The main commands used in the **Micra MAX** API are:

GET Used to obtain specific information or data from the probes and sensors connected to **Micra MAX**.

POST Used to send information or perform specific actions on the **Micra MAX** hardware.

DELETE Used to delete or deactivate resources or configurations in **Micra MAX**.

QUICK START GUIDE : See our portal : MICRAMAX.DITEL.ES/MICRA_MAX_API

• Error codes or Response

- **200** : Succes
- **201** : Succes Creation
- **400** : Invalid Request
- **401** : Unauthorized
- **404** : Resorce not found

• Endpoints

- `/v1/get_display` Receive information from the display (GET)
- `/v1/reset_tare` Reset tare (POST)
- `/v1/reset_max` Reset Max (POST)
- `/v1/reset_min` Reset Min (POST)
- `/v1/tare` Tare (POST)
- `/v1/factory_reset` Factory Reset (POST)
- `/v1/get_info` Get information from device (GET)
- `/v1/get_config` Receive configuration from device (GET)
- `/v1/post_config` Send a configuration to the device (POST)

MQTT (Exploring the Essentials for IoT Communication)

INTRODUCTION TO THE MQTT PROTOCOL

The MQTT (Message Queuing Telemetry Transport) Protocol is a lightweight and efficient messaging protocol, widely used in the Internet of Things (**IoT**). Its design facilitates communication in environments where low latency, minimal bandwidth consumption, and energy efficiency are required, which is essential for connected devices with limited resources.

What is MQTT?

MQTT is a messaging protocol based on the publish-subscribe model. It was designed in 1999 by Andy Stanford-Clark from IBM and Arlen Nipper from Arcom (now Eurotech), aiming to connect oil and gas systems over satellite connections with limited bandwidth and high latency. Today, it is used in a wide range of applications, from home automation to industrial telemetry.

Publish-Subscribe Model

The publish-subscribe model of MQTT is simple yet powerful. In this model, "clients" can subscribe to specific "topics" provided by an MQTT "broker". Other clients can publish messages on these topics, and the broker is responsible for distributing the messages to all clients subscribed to the corresponding topic.

Key Components of MQTT

MQTT Client:

A device or application that can publish messages to other clients and/or subscribe to topics to receive messages.

MQTT Broker:

A server that receives all messages from the clients and then distributes them to the subscribed clients based on the topics they have subscribed to.

Topic: A message identifier that clients use to filter the messages they need to receive. Topics can have multiple levels of hierarchy.

Operational Scheme

Connection: A client connects to the broker by providing a unique identifier and, optionally, authentication credentials.

Subscription: The client subscribes to one or more topics with the broker.

Publication: Another client publishes a message on a specific topic.

Distribution: The broker receives the message and distributes it to all clients subscribed to the specific topic.

Reception: The subscribed clients receive the message.

Benefits of MQTT

Efficiency: Uses minimal bandwidth and is ideal for networks with limited resources.

Decoupling: The producers and consumers of messages are decoupled, meaning they do not need to know each other.

Scalability: Capable of handling thousands of devices simultaneously.

Reliability: Offers different levels of quality of service to ensure message delivery.

You can find all the informations at micramax.ditel.es

MQTT (Exploring the Essentials for IoT Communication)

ENHANCING CONNECTIVITY WITH MICRA MAX AND MQTT

The **Micra MAX**, as a panel indicator and automation measurement device, offers a significant enhancement for users needing advanced communication solutions. This device supports MQTT communication when equipped with an Ethernet communication option. This option is a peripheral that can be connected to the **Micra MAX** motherboard and is typically sold together with the device.

Enabling MQTT on Micra MAX

To enable MQTT communication on the **Micra MAX**, users need to install the Ethernet communication option. Once installed, data generated by the **Micra MAX** can be sent to an MQTT broker for storage or further analysis. This setup allows for efficient data handling and integration into broader data management and analysis systems.

Configuration Steps

To activate and configure MQTT communication:

Accessing the Web Server: Navigate to the communications section on the Micra Max web server.

Activating MQTT: Select the option to enable MQTT communication.

Configuration Settings: Enter the necessary details to establish the connection. These details include:

MQTT Broker URL: `mqtt://ditel2.seoxan.es` (Note: It is crucial to include "mqtt://" in the URL).

Username and Password: These credentials are required for authentication with the broker.

Transmission Frequency: Set how often the **Micra MAX** sends data to the broker (coming soon).

Setting Up a Broker Account

To utilize our MQTT server for the **Micra MAX**, users must create an account at broker.ditel.es. This account allows users to manage their device connections securely and to handle the data transmitted via MQTT.

By connecting the **Micra MAX** to an MQTT broker via the Ethernet option, users can greatly enhance the device's functionality, making it a powerful tool for real-time data integration and analysis in various industrial applications.

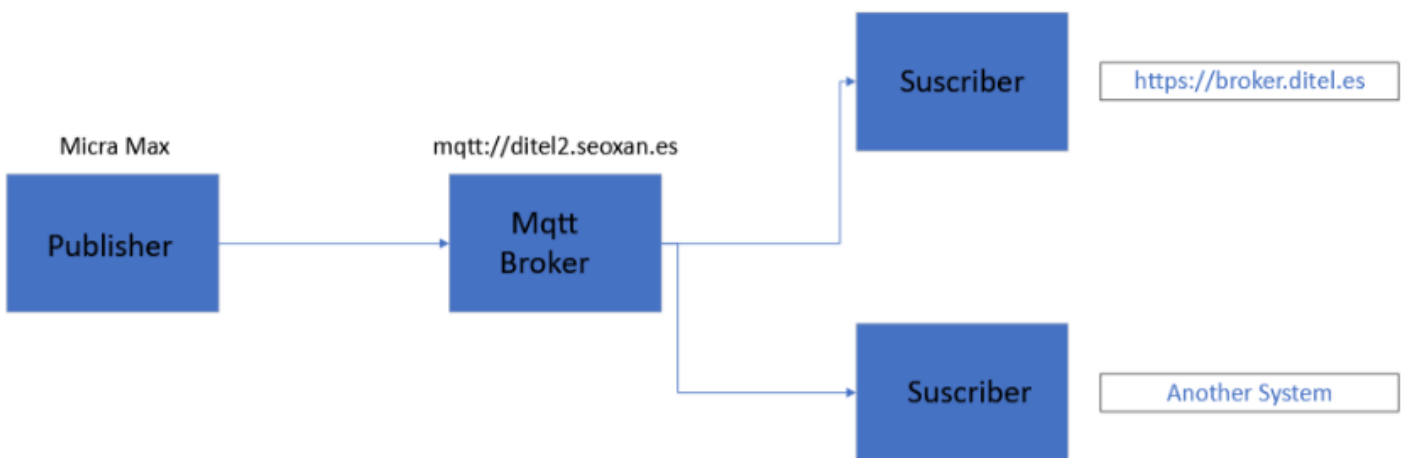

MQTT CONFIGURATION by WEB SERVER

Go to our portal micramax.ditel.es and select: **MQTT Ditel Cloud**

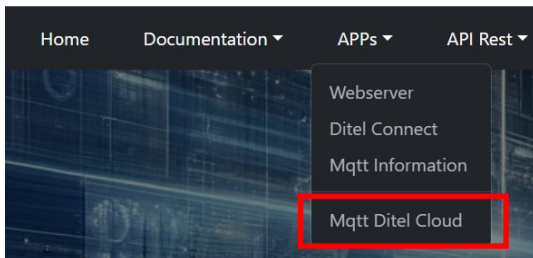

Log in with email and **password** for enter to : **MQTT Broker** then the screen below appears:

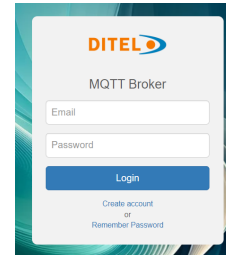

Password:
The password must contain at least 1 uppercase letter, 1 lowercase letter and 1 number

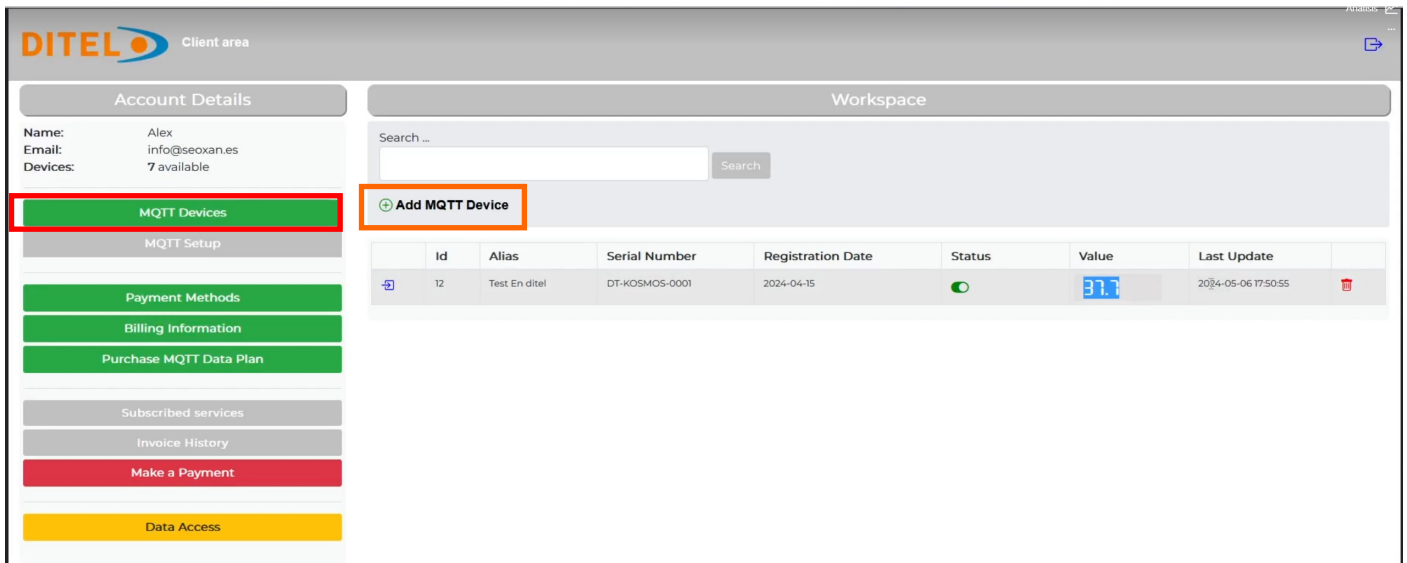

MQTT Devices : The screen shows us the account details (name and email) and the number of devices we have registered. (We can select them using the *Search* button).

For each device it gives us information about:

Id, Alias, Serial Number, Registration Date, Status, Value and Last Update.

If we want to add other new devices, we must click on: "Add MQTT Device".

We will give them an "Alias" and a "Serial Number" before saving, and they will be incorporated into the MQTT Devices screen.

On this screen we will always have the last up date of the device's display value.



MQTT CONFIGURATION

MQTT Set Up

These are the instructions for configuring your device via webserver and connecting it to our system. You will need to access your device through the web server and navigate to the communications section. Within this section, you will find fields to complete, such as the MQTT server, username, and password. Please make sure to note this information:

Server : mqtt://ditel2seoxan.es

Port : 1883

User : info@seoxan.es

Password : Same password you use in this area

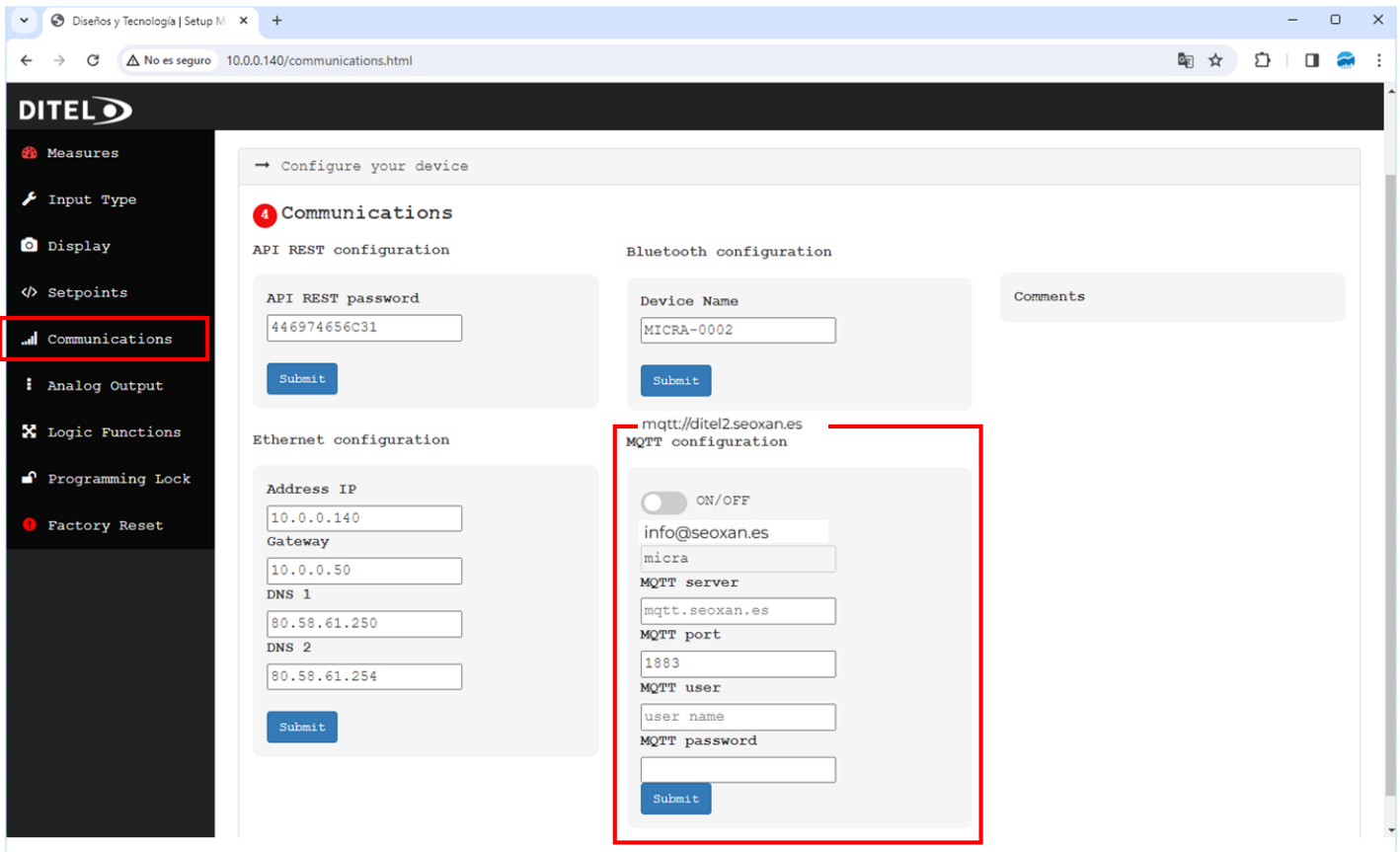

ENGLISH

ON/OFF: Switch to enable or disable the MQTT configuration.

Device Family: Pre-configured text field with the value "MICRA", not editable.

MQTT configuration is essential for integrating the device into automation systems or IoT platforms that use the MQTT protocol for communication.

DITEL MQTT BROKER CONFIGURATION

Billing Information

Account Details

Name: Alex
Email: info@seoxan.es
Devices: 7 available

MQTT Devices
MQTT Setup
Payment Methods
Billing Information
Purchase MQTT Data Plan
Subscribed services
Invoice History
Make a Payment
Data Access

Workspace

Your billing information

Tarde Name: SeoXan

Tax Name: SeoXan Tech S.L.

VAT Number: B56914286

Address: Narcisa Freixas 5

City: Sabadell

Country: Pais

Post Cod: 08202 State: State

Phone: 610966748

Save

In **Billing Information** we must enter the data that will appear on the generated invoice if we have contracted a service such as **MQTT Data Plan**.

Next we will have to choose a **Payment Method**.

Datos de cuenta

Name: Alex
Email: info@seoxan.es
Devices: 7 available

MQTT Devices
MQTT Setup
Payment Methods
Billing Information
Purchase MQTT Data Plan
Subscribed services
Invoice History
Make a Payment
Data Access

Workspace

We have several payment methods available from the client area

Bank Transfer
You can make a payment via bank transfer to:
Beneficiary: Diseños y tecnología S.A
Account number: ES75 XXXX XXXX XXXX XXXX XXXX
BIC: BSABSAXXX

PayPal
You can make a payment via PayPal by stating our PayPal account number. You can pay any of your outstanding invoices with PayPal through the option 'Make a Payment'
PayPal Acc.: paypal@ditel.es

Direct debit through the bank
We can automatically charge a bill upon its due date if you provide us with the signed SEPA document.
More information: <https://www.sepa.es/sep/es/faq/lelmandato/>
IBAN Number: 1
Swift BIC (8 o 11 Char): 2
Download SEPA doc: 3
Sign this document digitally: 4

Credit Card Payment
You can pay any of your outstanding invoices with a credit card through the option 'Make a Payment'

They are now activated:

- **PayPal**

They are **not** operational at the moment:

- Bank Transfer
- Direct Debit through the Bank
- Credit Card Payment

MQTT CONFIGURATION by WEB SERVER

Purchase MQTT Data Plan

If you select **Free Plan**, you must enter the **Coupon Code** that is delivered with each of the units of **MICRA-M MAX**, this code decrypts the Serial Number of the device, when "*Subscribing*" it is generated on the screen **MQTT Devices** the device and allows you to view the display value, but not the history. The rest of the Plans will appear on the screen as they are created. (example **not valid** at cost level: **Annual Basic Plan**)

ENGLISH

Suscribed Services

ID	Order Date	Order	Amount	Dast Date	Days	Next Due Date	Status	Request Cancellation
65	2024-04-16	Basic Plan	30.25€	21-04-2024	+35 dias	21-04-2025	Anual	
64	2024-04-12	Basic Plan	30.25€	17-04-2024	+39 dias	17-04-2025	Anual	
63	2024-04-11	Basic Plan	30.25€	16-04-2024	+40 dias	16-04-2025	Anual	
62	2024-04-11	Basic Plan	30.25€	16-04-2024	+40 dias	16-04-2025	Anual	
61	2024-04-11	Basic Plan	30.25€	16-04-2024	+40 dias	16-04-2025	Anual	
60	2024-04-11	Basic Plan	30.25€	16-04-2024	+40 dias	16-04-2025	Anual	
59	2024-04-11	Basic Plan	30.25€	16-04-2024	+40 dias	16-04-2025	Anual	
58	2024-04-11	Basic Plan	30.25€	16-04-2024	+40 dias	16-04-2025	Anual	
57	2024-04-11	Basic Plan	30.25€	11-04-2024	+45 dias	11-04-2025	Anual	

*** La cancelación de servicios no es posible dentro de los 15 días previos a su renovación. Agradecemos su comprensión. ***

This screen will show the contracted Services, with the details of:

- Plan Identification (contract date and name)
- Amount
- Date of hire
- Date of renovation

In the "Request Cancellation" column we can cancel a Plan if it is no longer of interest to us.

MQTT CONFIGURATION by WEB SERVER

Invoice History

Factura	Fecha	Vencimiento	Importe	Pedido	Estado	Forma de pago
12549	2024-04-16	2024-04-16	30.25€	Basic Plan	Pendiente pago	Contado Paypal Visa
12548	2024-04-12	2024-04-12	30.25€	Basic Plan	Pendiente pago	Contado Paypal Visa
12547	2024-04-12	2024-04-12	30.25€	Basic Plan	Pendiente pago	Contado Paypal Visa
12546	2024-04-12	2024-04-12	30.25€	Basic Plan	Pendiente pago	Contado Paypal Visa
12545	2024-04-11	2024-04-11	30.25€	Basic Plan	Pendiente pago	Contado Paypal Visa
12544	2024-04-11	2024-04-11	30.25€	Basic Plan	Pendiente pago	Contado Paypal Visa
12543	2024-04-11	2024-04-11	30.25€	Basic Plan	Pendiente pago	Contado Paypal Visa
12542	2024-04-11	2024-04-11	30.25€	Basic Plan	Pendiente pago	Contado Paypal Visa
12541	2024-04-11	2024-04-11	30.25€	Basic Plan	Pendiente pago	Contado Paypal Visa
12540	2024-04-11	2024-04-11	30.25€	Basic Plan	Pendiente pago	Contado Paypal Visa
12539	2024-04-11	2024-04-11	30.25€	Basic Plan	Pendiente pago	Contado Paypal Visa
12538	2024-04-11	2024-04-11	30.25€	Basic Plan	Pendiente pago	Contado Paypal Visa
12537	2024-04-11	2024-04-11	30.25€	Basic Plan	Pendiente pago	Contado Paypal Visa
12536	2024-04-11	2024-04-11	30.25€	Basic Plan	Pendiente pago	Contado Paypal Visa

If you select **Invoice History** you will obtain an invoice history with the following details:

- Invoice No., Invoice Date, Due Date, Amount
- Name of the Service, Status (pending payment or paid), Payment method.

If you want to obtain a copy of the invoice, you can click on the "printer" icon.

Make a Payment

Make a paypal with paypal

Select the invoice: -- Select --

- Invoice: 12549 - Payment by paypal: 30.25 EUR
- Invoice: 12548 - Payment by paypal: 30.25 EUR
- Invoice: 12547 - Payment by paypal: 30.25 EUR
- Invoice: 12546 - Payment by paypal: 30.25 EUR
- Invoice: 12545 - Payment by paypal: 30.25 EUR
- Invoice: 12544 - Payment by paypal: 30.25 EUR
- Invoice: 12543 - Payment by paypal: 30.25 EUR
- Invoice: 12542 - Payment by paypal: 30.25 EUR
- Invoice: 12541 - Payment by paypal: 30.25 EUR
- Invoice: 12540 - Payment by paypal: 30.25 EUR
- Invoice: 12539 - Payment by paypal: 30.25 EUR
- Invoice: 12538 - Payment by paypal: 30.25 EUR
- Invoice: 12537 - Payment by paypal: 30.25 EUR
- Invoice: 12536 - Payment by paypal: 30.25 EUR

This screen will show the systems to pay the invoices, now only **PayPal** is activated.

Once the system is selected, all the invoices that are pending payment will be displayed on the screen, we can select which one we want to pay and when making the payment its status in **Invoice History** will change as paid.

MQTT CONFIGURATION by WEB SERVER

Data Acces

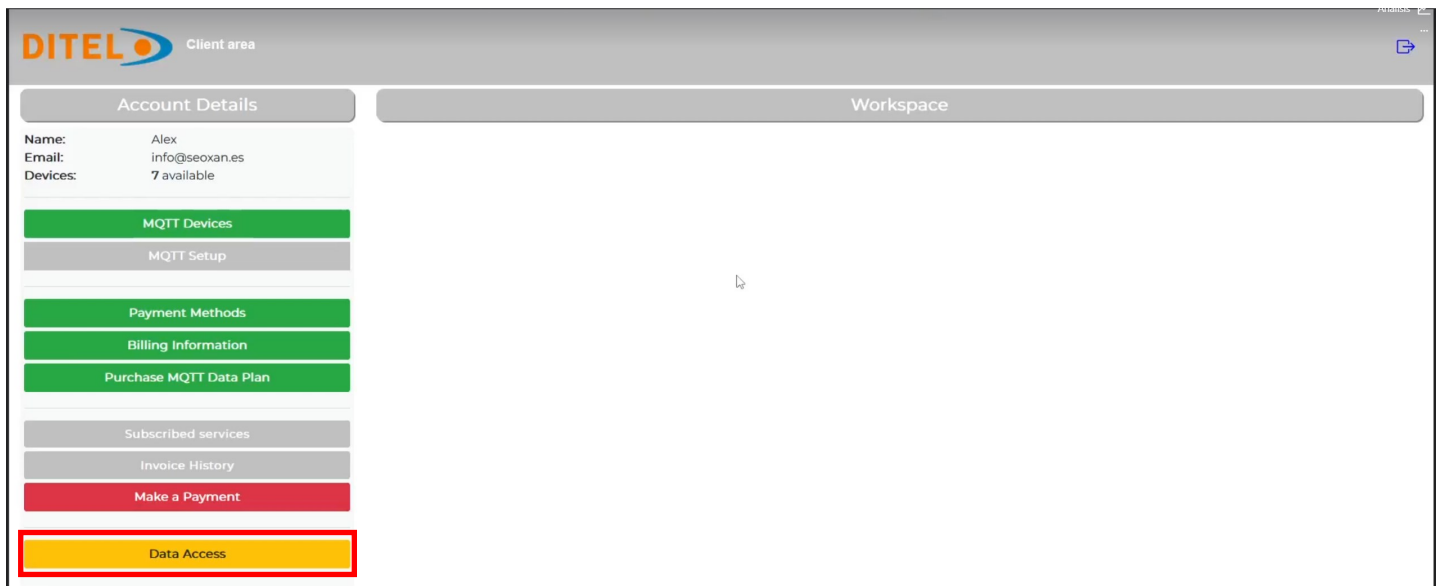

The screenshot shows the DITEL Client area interface. The top navigation bar includes the DITEL logo and 'Client area'. Below this, there are two main sections: 'Account Details' and 'Workspace'. The 'Account Details' section contains a table with the following information:

Name:	Alex
Email:	info@iseoxan.es
Devices:	7 available

Below the table, there is a list of menu items:

- MQTT Devices (green button)
- MQTT Setup (grey button)
- Payment Methods (green button)
- Billing Information (green button)
- Purchase MQTT Data Plan (green button)
- Subscribed services (grey button)
- Invoice History (grey button)
- Make a Payment (red button)
- Data Access (yellow button, highlighted with a red border)**

Finally, by selecting **Data Access** you will obtain complete information about the selected device with:

- History of measurements with date and time according to the Selected Plan
- Graphs showing the evolution of the supervised variable
- Trends as a function of time or the value of the variable

NOTE: The presentation and type of information is in the design phase and may differ from what is described above.

ANALOG OUTPUT CONFIGURATION by WEB SERVER

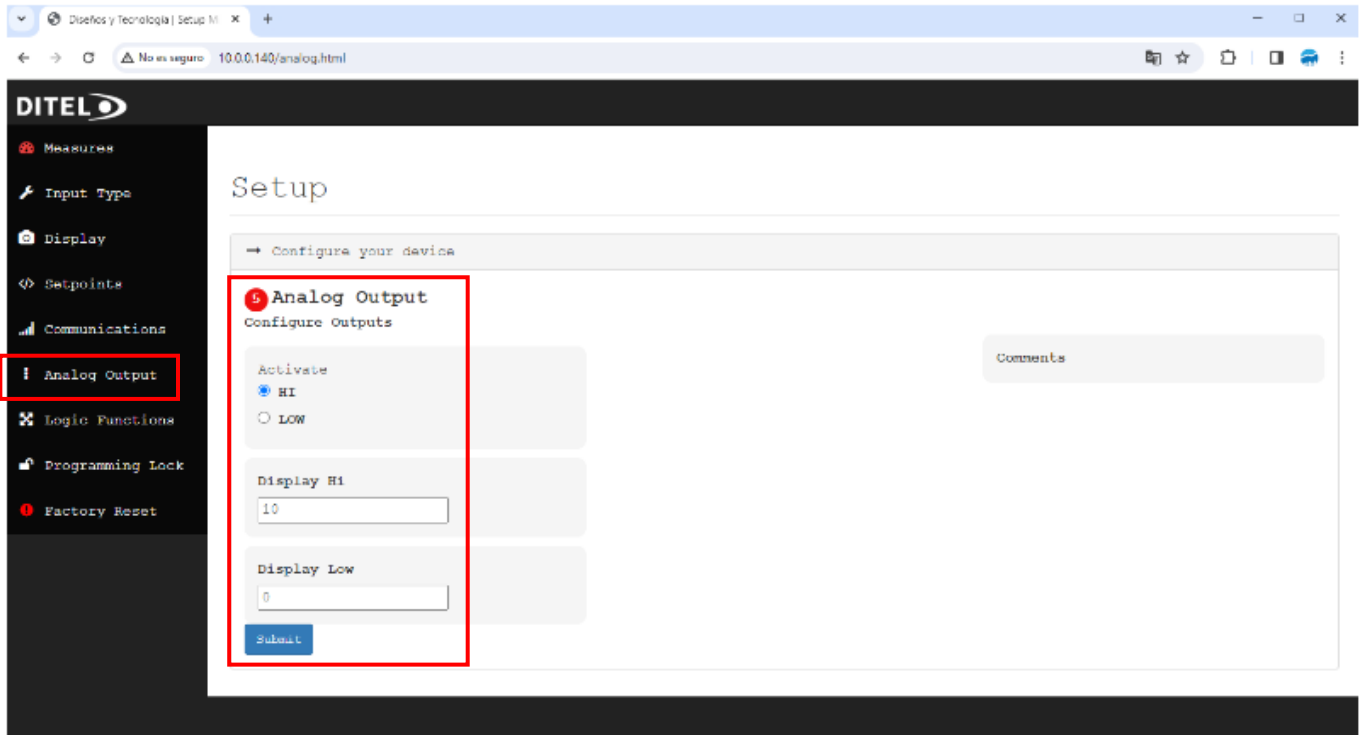

ENGLISH

The analog output settings in the **Micra-M MAX** software enable the device to output analog signals corresponding to measured values, facilitating integration with external control systems or recording devices. This section guides you through the configuration process.

Accessing Analog Output Configuration

To configure the analog output settings:

From the main dashboard, navigate to the "Analog Output" section.

The configuration panel presents several options to customize the analog output according to your requirements.

Configuration Options

The key settings available for analog output configuration include:

Activation: Toggle the analog output between active (HI) or inactive (LOW) states, controlling whether the output signal is enabled.

Display Hi: Set the upper limit for the analog output range. This value corresponds to the maximum signal output, typically represented in engineering units related to your measurement (e.g., psi, °C, etc.).

Display Low: Define the lower limit for the analog output range, which corresponds to the minimum signal output.

Submitting Your Configuration

After adjusting the settings to match your operational parameters:

Review all entered values to ensure they align with your system's requirements.

Click the "Submit" button to apply and save your analog output configurations

LOGIC FUNCTION CONFIGURATION by WEB SERVER

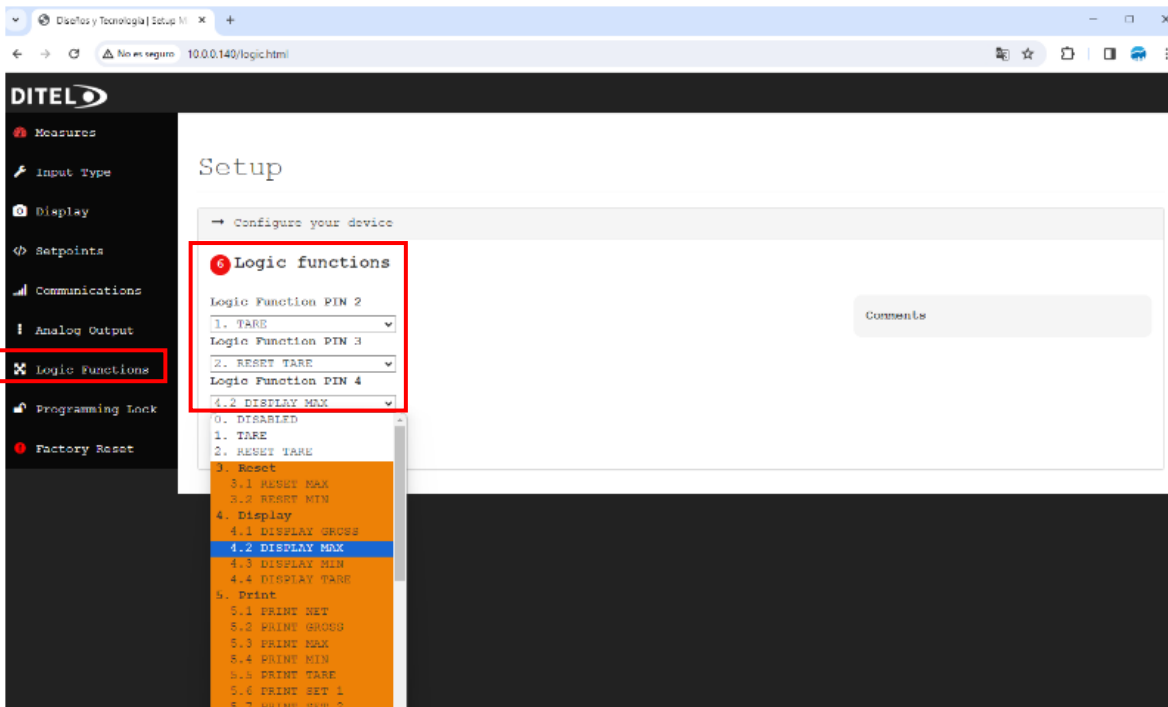

The **Micra-M MAX** software provides the ability to configure logic functions, enhancing the device's interactivity and responsiveness to user inputs. This section guides you through configuring these functions for Pins 2, 3, and 4.

Accessing Logic Function Configuration

To access and configure the logic functions:

Navigate to the "Logic Function" section from the main dashboard.

You'll be presented with options to configure the logic functions for Pins 2, 3, and 4.

Configuration Options for Pins

Each pin can be configured with a specific logic function from the following categories:

Disabled: Turn off any function for the pin.

Tare and Reset Tare: Manage tare settings directly through pin inputs.

Reset: Options to reset maximum, minimum, or other specific parameters.

Display: Change what is currently being displayed (e.g., gross, net, maximum, minimum, tare).

Print: Trigger printouts of measurements or setpoint statuses.

Hold Display: Freeze the current display.

Brightness: Adjust the display brightness between high and low settings.

Change Display Color: Modify the display color to orange, red, or green for visual cues.

Write: Set specific values to tare or setpoints directly through pin inputs.

False Setpoints: Implement temporary setpoint values for testing or other purposes.

Keys Repetition: Allow repeated actions through continuous input.

Reserved: Functions set aside for future use or specific customization.

Submitting Your Configuration

After selecting the desired functions for each pin:

Review your configurations to ensure they meet your operational needs.

Click the "Submit" button to apply and activate the logic functions.

LOCK OUT PROGRAMMING by WEB SERVER

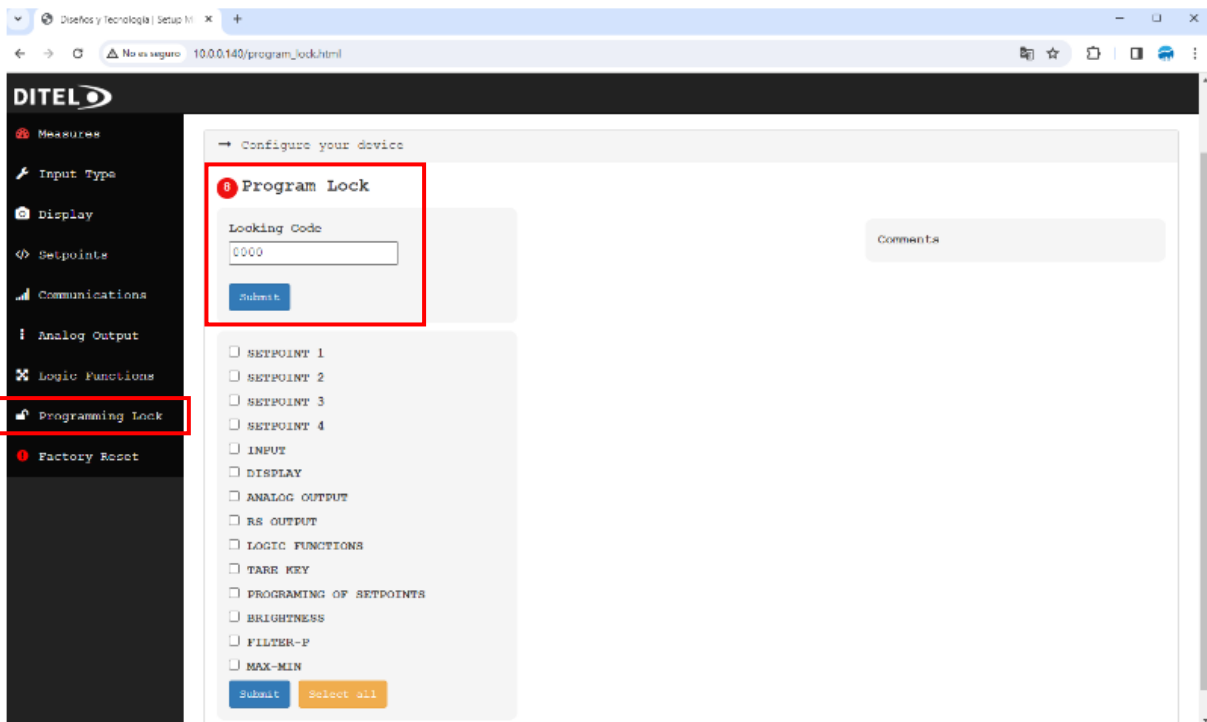

- To safeguard your device's programming configurations, the **Micra-M MAX** software includes a program lock feature. This function restricts access to critical programming settings, ensuring only authorized users can make changes.

Accessing Program Lock Configuration

From the main dashboard, navigate to the "Programing Lock" section.

You will be prompted to enter the current lock code to access the configuration settings. This code is either the default set by the manufacturer or one that you have previously established.

Setting the Program Lock

After entering the correct code:

- Choose which settings you wish to lock. Options include:
 - Setpoints 1 through 4
 - Input configuration
 - Display settings
 - Analog output settings
 - RS output settings
 - Logic functions
 - The tare key functionality
 - Programming of setpoints
 - Display brightness
 - Filter-P settings
 - Max-Min value reset and display
- You can select individual items or use the "Select all" option to lock all programmable settings.
- After making your selections, click "Submit" to apply the locks.

SECURITY MENU BY WEBSERVER

To Change Lock Settings: You must enter the correct lock code to adjust which programming features are locked or unlocked.

To Modify the Lock Code: Refer to the "*Locking Code*" section of this manual for instructions on changing the program lock code.

FACTORY RESET by WEB SERVER

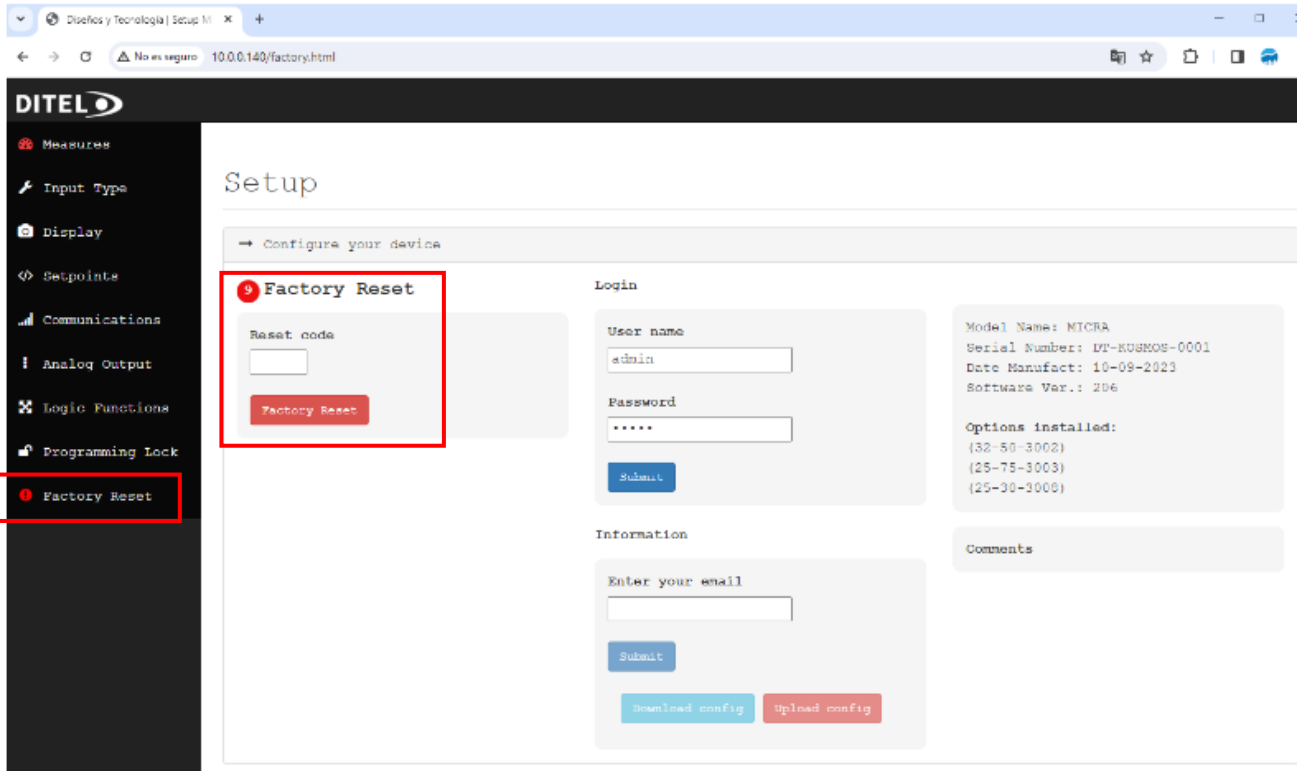

A factory reset restores the **Micra-M MAX** software to its original settings, erasing all custom configurations. This procedure should be used cautiously, as it will remove all current settings and **data**.

Initiating Factory Reset

Navigate to the "Factory Reset" section from the main dashboard.

You will be prompted to enter a code to proceed with the factory reset. This code ensures that the reset is conducted by an authorized user. Enter the provided code in the "Enter the code" field.

After entering the correct code, select the "*Factory Reset*" button to initiate the reset process.

Confirming the Reset

A confirmation dialog may appear to prevent accidental resets. Confirm your intention to proceed with the factory reset.

Changing the Webserver Password

In addition to factory reset instructions, this section includes steps to change the webserver password:

- Go to the "*Change password*" subsection within the factory reset page.
- Enter your new desired password in the "*Enter new password*" field.
- Submit the change by clicking the "*Submit*" button.

Information

Allows the user to download the complete configuration or upload a configuration file. Is very useful when you communicate with our Support Service, or to store securely your configuration.

PROGRAMMING MODE by KEYBOARD

First, plug the instrument to the corresponding supply, automatically a display test will be done and after that the software version will be shown then the instrument will go to work mode. Second, press the key to enter into the programming mode, the indication "-Pro-" will appear on the display then.

How to store programmed parameters?

If we want to save the changes that we have done in the programming, we must complete the programming of all the parameters contained in the routine we are in. In the last step of the routine, as a result of pressing on the key, "StorE" will be displayed during a few seconds, meanwhile all the data are stored in memory. Then the instrument will go back to working mode.

How is programming routine organised?

Programming software is composed by a number of menus and submenus hierarchically organized. On figure below, beginning with indication "-Pro-", press repeatedly to get access to programming menus. Modules 3, 4 and 5 will only be shown if the option for setpoints, analogue output, RS option or Ethernet option has been plugged in. Selecting one menu, the access to the different programming submenus is done by pressing .

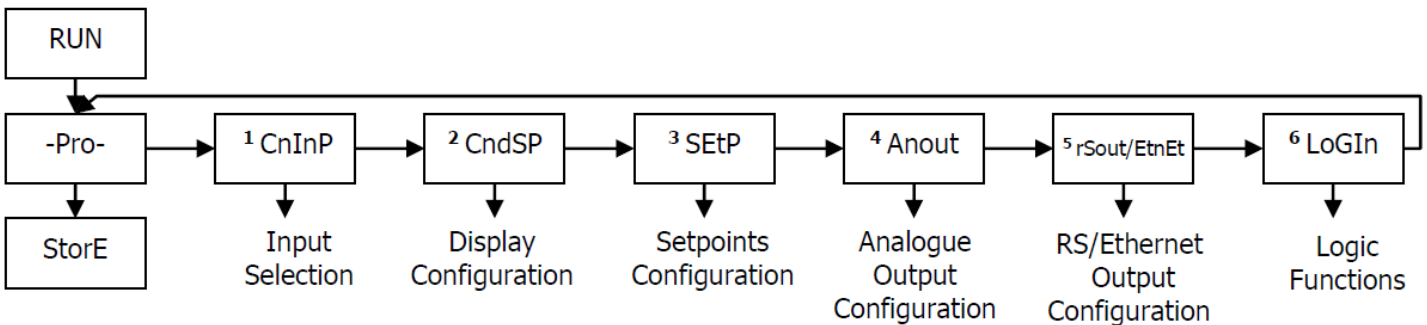

ENGLISH

Accessing to programmed parameters

Thanks to the tree structure, the programming routines allow to access to change one parameter without passing through the whole list of parameters.

To advance through programming

The progress through the programming routines is done by pressing key.

In general, the steps to be done will be push key a certain number of times to select an option and push key to validate the change and going forward to the next step of the program. The numerical values are programmed digit by digit as explained in the next paragraph.

Programming numerical values

When the parameter is a numerical value, the display will show the first of the digit to be programmed blinking. The method of introducing a value is as follow:

Digit selecting: Press repeatedly the key to shift from left to right over all the display digits.

Changing the digit value: Press repeatedly the key to increase the value of blinking digit until it has the desired value.

The minus sign is programmed depending on the variable type. A variable that represents the value of an input will be able to take a value in the range -19999 to 99999, without taking into account the decimal point. When change the first digit, this shows values from (0) to (9), and then (-1), (-), and comes back to show values from 0 to 9. A variable that represents a display value will be able to take a value in the range -19999 to 99999, without taking into account the decimal point.

Selecting an option from the list

When the parameter is an option to be chosen among different possibilities, the key allows you to browse through the list of options until you find the desired parameter

POWER SUPPLY and CONNECTORS

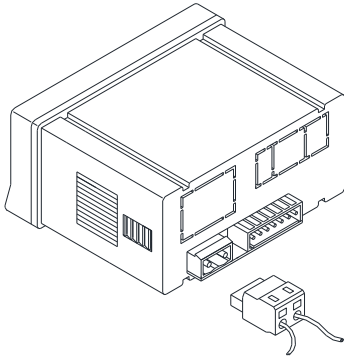

WARNING: If not installed and used in accordance with these instructions, protection against hazards may be impaired.

In order to guarantee the electromagnetic compatibility, the following guidelines should be kept in mind:
 Power supply wires may be routed separated from signal wires.
 Never run power and signal wires in the same conduit.
 Use shielded cable for signal wiring and connect the shield to the ground of the indicator. The cables section should be $\geq 0.25 \text{ mm}^2$

INSTALLATION

To meet the requirements of the directive EN61010-1, where the unit is permanently connected to the mains supply, it is obligatory to install a circuit breaking device easy reachable to the operator and clearly marked as the disconnect device.

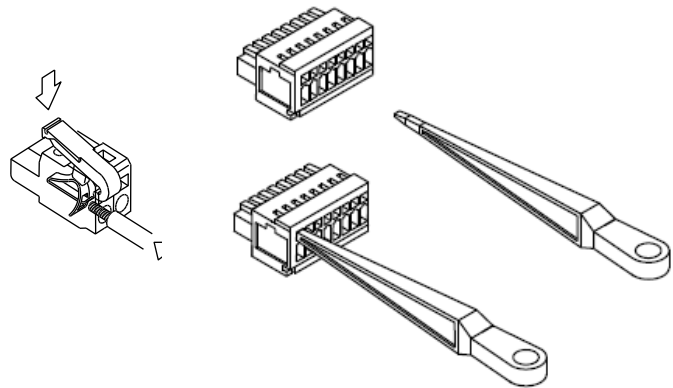
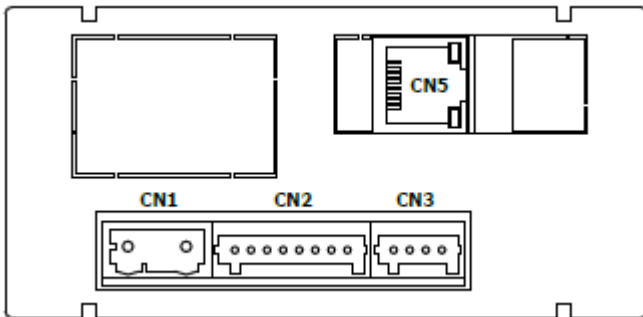

ENGLISH

WIRING and POWER SUPPLY RANGE

MICRA-M MAX
 85 V – 265 V AC 50/ 60 Hz or 100 – 300 V DC
MICRA-M6 MAX
 22 – 53 V AC 50/ 60 Hz or 10,5 - 70 V DC

Borne 1: Phase
 Borne 2: Neutral

NOTE: When DC power supply (direct), polarity in connector CN1 is indistinct.

CONNECTORS

CN1 To perform wiring connections, strip the wire leaving from 7 and 10 mm exposed to air and insert it in the proper terminal while pushing the fingertip down to open the clip inside the connector as indicated in the figures. Each terminal accepts cables of section between 0.08 mm^2 and 2.5 mm^2 (AWG 26 ÷ 14).

CN2 & CN3 To perform wiring connections, strip the wire leaving from 5 and 6 mm exposed to air and insert it in the proper terminal while pushing the fingertip down to open the clip inside the connector as indicated in the figures. Each terminal accepts cables of section between 0.08 mm^2 and 0.5 mm^2 (AWG 28 ÷ 20).

CN5 RJ45 connector for Ethernet cable

Instrument frontal view

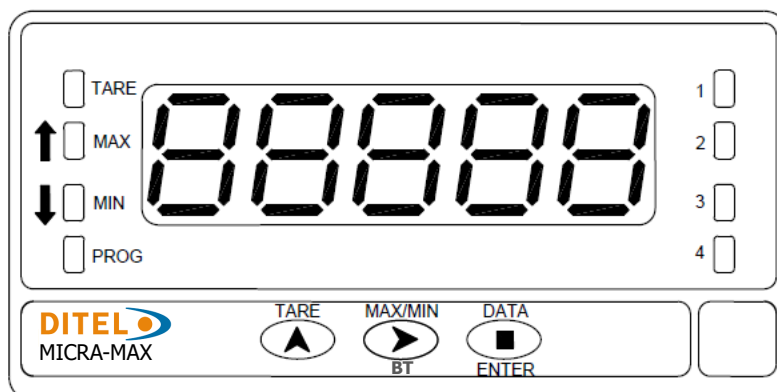

Programming guide

The different steps to be followed for a correct programming of each type of function are detailed below. The reading and application of some paragraphs are obligatory (O), recommendable (R) or optional (op).

As Process indicator:

1. Input Configuration, (O).
2. Input Connection, (O).
3. Display Configuration, (O).
4. Program remote inputs, (R).
5. Install and configure output option(s) (op)
6. Programming lock-out, (R).

As Load cell indicator

1. Input Configuration, (O).
2. Input Connection, (O).
3. Display Configuration, (O).
4. Program remote inputs, (R).
5. Install and configure output option(s) (op).
6. Programming lock-out, (R).

As thermometer Pt100:

1. Input Configuration, (O).
2. Input Connection, (O).
3. Program remote inputs, (R).
4. Install and configure output option(s) (op).
5. Programming lock-out, (R).

As thermometer thermocouple:

1. Input Configuration, (O).
2. Input Connection, (O).
3. Program remote inputs (R).
4. Install and configure output option(s) (op).
5. Programming lock-out, 85 (R).

INPUT CONFIGURATION by KEYBOARD

The figure below shows the input configuration menu. Divided into four submenus, each one of them separated by the dotted line in the manual, each menu corresponds to the programming of the different types of input: process, load cell, thermometer Pt100 and thermometer thermocouple. The data requested in each case are indicated below.

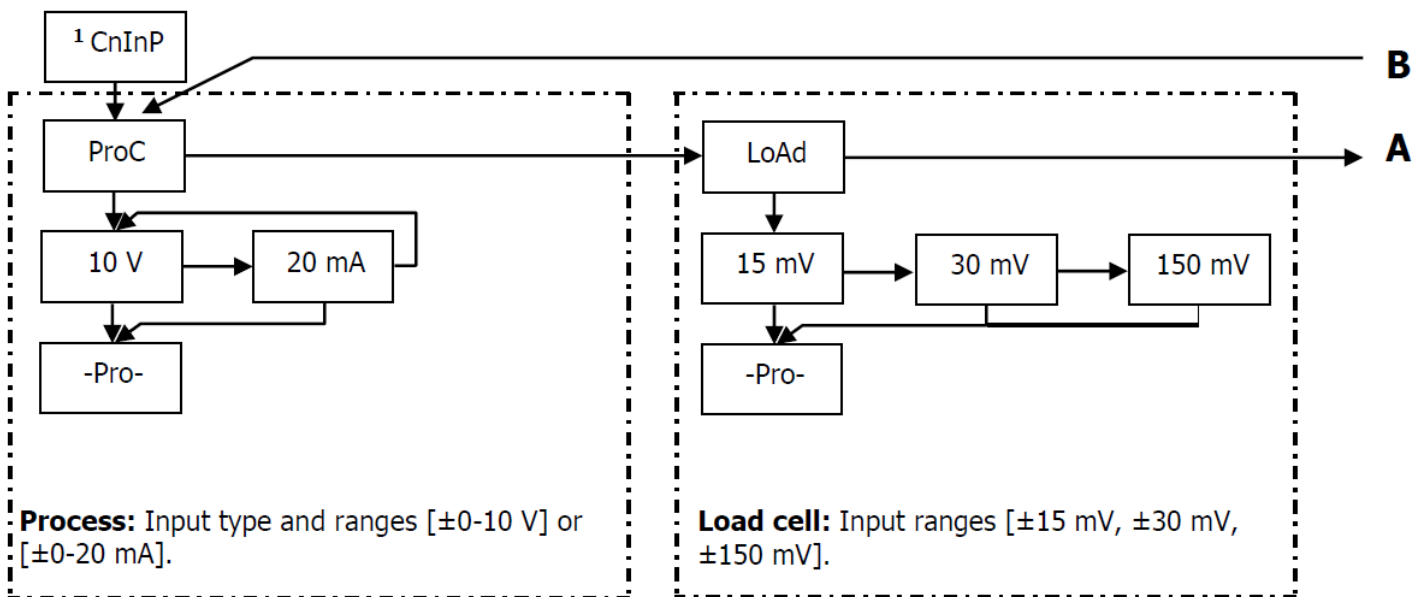

ENGLISH

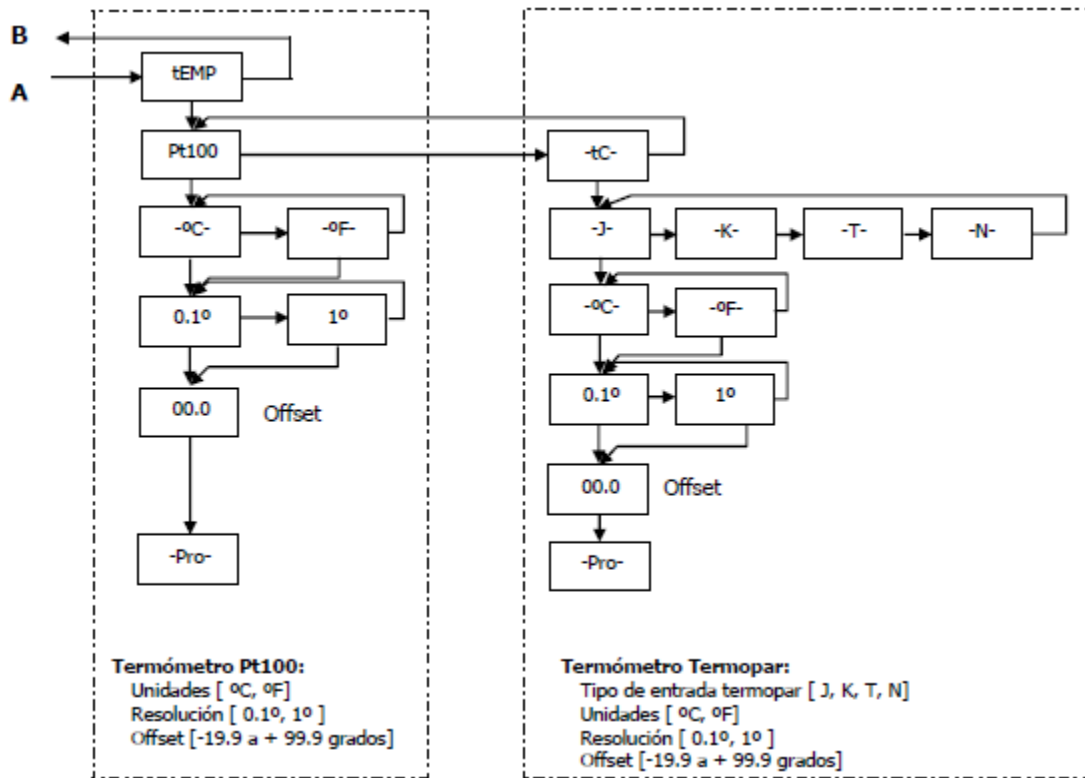

PROCESS INPUT PROGRAMMING by KEYBOARD

As process indicator it is designed to measure all kinds of process variable with direct indications in engineering units.

The parameter to configure as process indicator is the input type, in volts in a -10 V to 10 V range and in milliamperes in a -20 mA to 20 mA range.

TRANSDUCER WIRING (V, mA)

Refer to wiring guidelines

Instrument's rear view

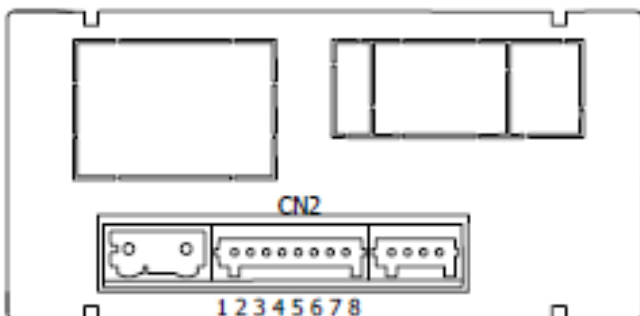

- CN2**
- PIN 1 = -EXC [excitation output (-)]
- PIN 2 = +EXC [excitation output +24V (+)]
- PIN 3 = +EXC [excitation output +5V or 10V (+)]
- PIN 4 = N/C [no connection]
- PIN 5 = +IN [input mA (+)]
- PIN 6 = +IN [input V (+)]
- PIN 7 = N/C [no connection]
- PIN 8 = -IN [input V (-), mA(-)]

WIRING DIAGRAM FOR INPUT mA ($\pm 0-20$ mA / 4-20 mA)

CONNECTION WITH EXT. EXCITATION

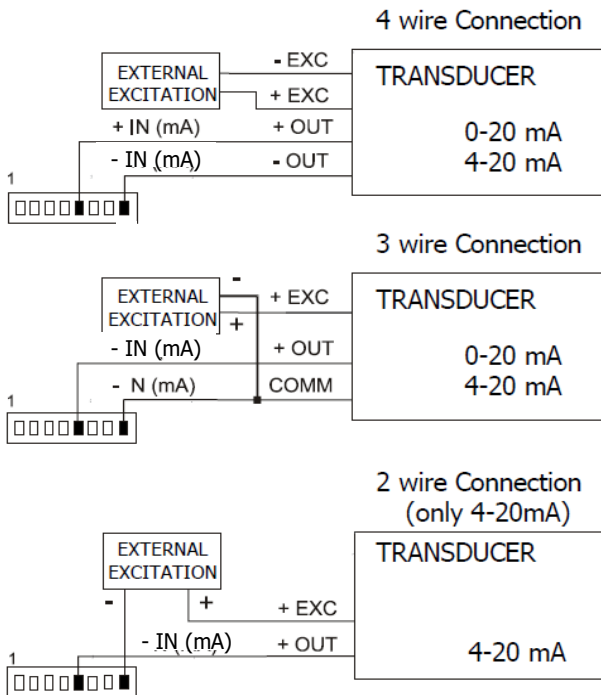

EXCITATION SUPPLIED BY MICRA-M

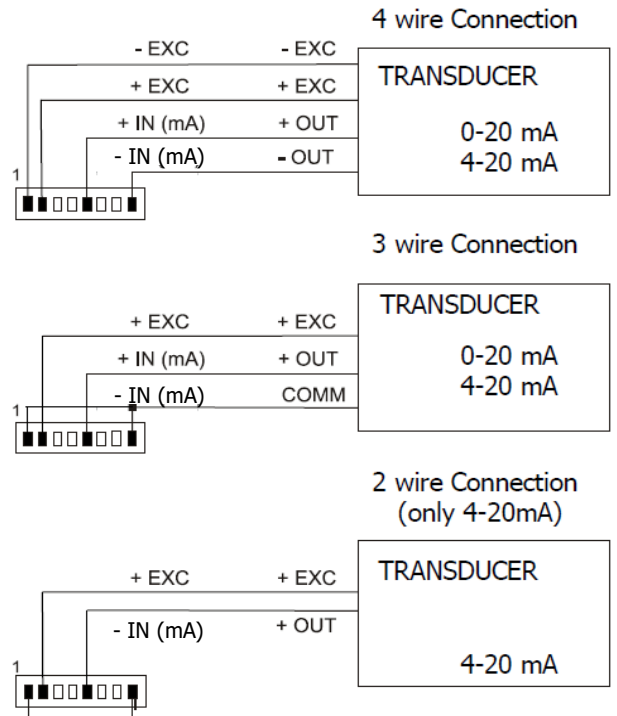

If the excitation supplied by **MICRA-M MAX** to the transducer has to be 10 or 5 V connect the + EXC wire to PIN3 instead of PIN2

WIRING DIAGRAM FOR INPUT V ($\pm 0-10$ V)

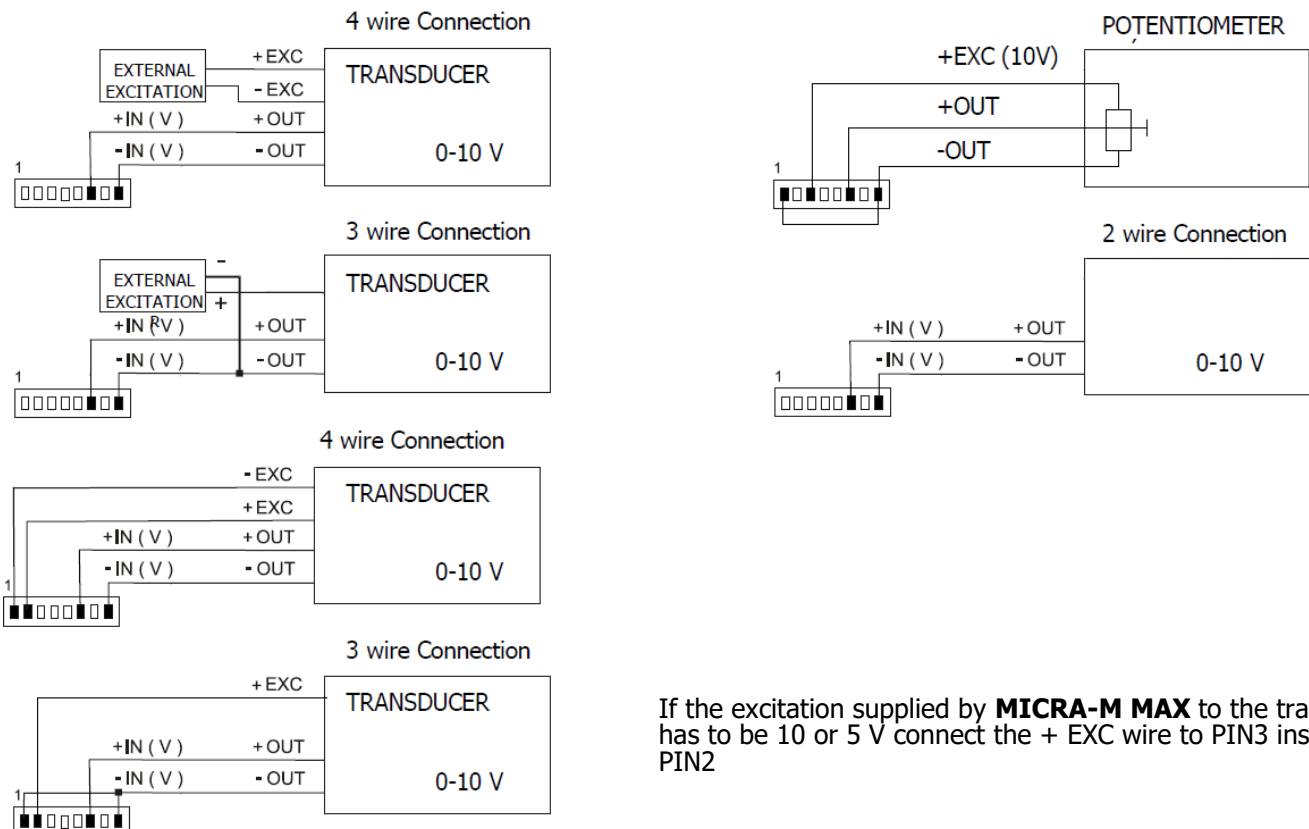

If the excitation supplied by **MICRA-M MAX** to the transducer has to be 10 or 5 V connect the + EXC wire to PIN3 instead of PIN2

ENGLISH

LOAD CELL INPUT PROGRAMMING by KEYBOARD

Refer to cell manufacturer's documentation, particularly with respect to the cell sensitivity and supply voltage specifications.

As load cell indicator the meter's function is to measure forces (weight, pressure, torque...) applied to a dispositive connected to several bridge type transducers such as load cell, which supply signal levels up to ± 150 mV. The two excitation voltages supplied by this instrument are 10 V and 5 V. The selection is realised through the configuration of the internal bridge excitation). This way up to 2 cells can be connected in parallel with 10 V excitation and up to 4 cells with 5 V excitation, without need for an external source.

Example:

2 cells with 2 mV/V sensibility are supplied with an excitation voltage of 10 V; the voltage generated by each cell at full load is 20 mV, being 20 mV the maximum as the cells are connected in parallel. In the same case but with a 5 V excitation, the maximum voltage generated will be 10 mV.

Software configuration requires selection of the input range which may be selected high enough for the maximum input signal to avoid overloads. There are three ranges: ± 15 mV, ± 30 mV and ± 150 mV

Example:

If a weighing process gives 12 mV to the meter input with maximum load, the best input range to select will be "15 mV".

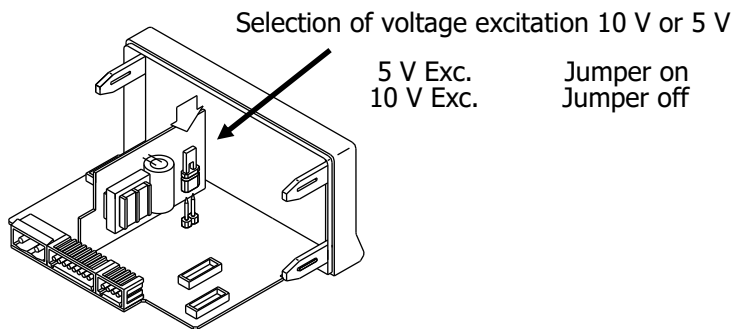

LOAD CELL WIRING (mV/ V)

Refer to wiring guidelines

Instrument's rear view

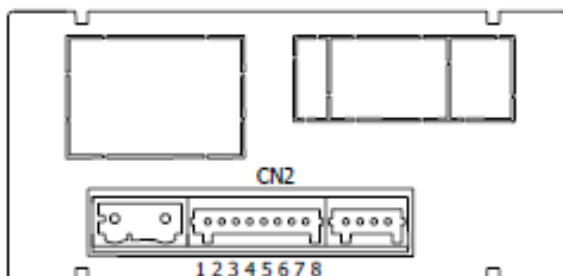

INPUT SIGNAL CONNECTOR

CN2

PIN 1 =	-EXC	[excitation output (-)]
PIN 2 =	+EXC	[no connection]
PIN 3 =	+EXC	[excitation output +5V or 10 V (+)]
PIN 4 =	N/C	[no connection]
PIN 5 =	N/C	[no connection]
PIN 6 =	N/C	[no connection]
PIN 7 =	+mV	[input mV (+)]
PIN 8 =	-mV	[input mV (-)]

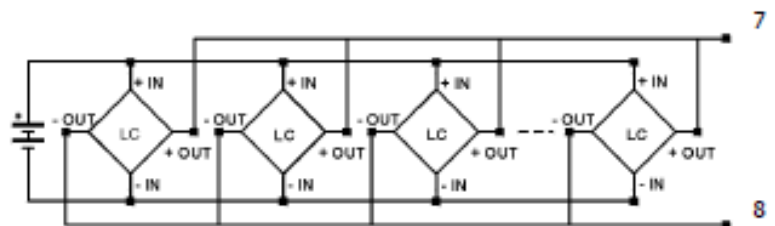
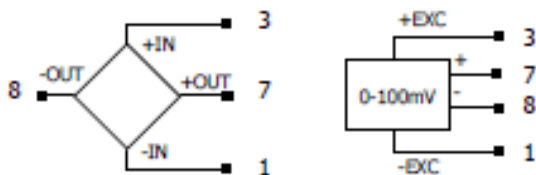

Pt100 INPUT PROGRAMMING by KEYBOARD

When configuring the meter as thermometer for 3 wires Pt100 sensors, the temperature ranges and resolution available are:

Input	Range (res. 0.1 °)	Range (res. 1°)
Pt100	-200.0 to +800.0 °C	-200 to +800 °C
	-328.0 to +1472.0 °F	-328 to +1472 °F

The Pt100 software menu allows selection of temperature units (Celsius or Fahrenheit), resolution (degree or tenth of degrees) and a display offset. Offset value is programmed if we know that a difference may exist between the temperature under measurement and the temperature read by the sensor. This difference can be corrected by programming an offset from -19.9 to +99.9.

LED TARE will light up each time that an offset value is programmed.

Example:

In a process of temperature control the Pt100 sensor is located in a part of the process where temperature is 10 degrees below than in the point in where the control has to be done. By programming an offset of 10 points, with 1 degree resolution, the deviation will be corrected.

Configurable parameters for this input are:

- d) Reading units in degree Celsius "°C" or Fahrenheit "°F".
- e) Resolution in tenth of degrees "0,1°" or in whole degrees "1°".
- f) Offset. The instrument comes from factory with offset=0

After entering these parameters, the display range and linearization are adjusted automatically.

Pt100 INPUT WIRING

Instrument's rear view

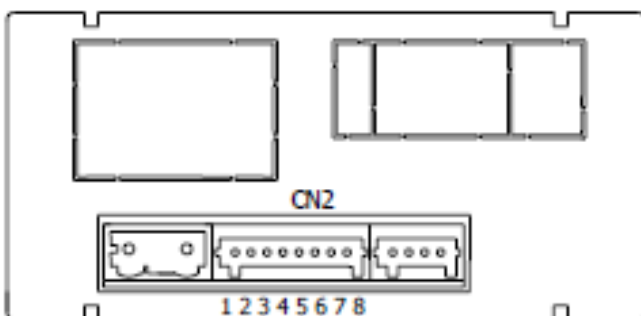

INPUT SIGNAL CONNECTOR

CN2

- PIN 1 = No connection
- PIN 2 = No connection
- PIN 3 = No connection
- PIN 4 = Pt100 A
- PIN 5 = No connection
- PIN 6 = No connection
- PIN 7 = Pt100 B
- PIN 8 = Pt100 B

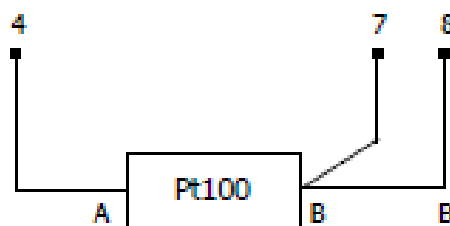

THERMOCOUPLE INPUT PROGRAMMING by KEYBOARD

When configuring the meter for thermocouple input, the temperature ranges and resolution available are :

Input	Range (res. 0,1 °)	Range (res. 1°)
Thermocouple J	-150,0 to +1100,0 °C	-150 to +1100 °C
	-238,0 to +2012,0 °F	-238 to +2012 °F
Thermocouple K	-150,0 to +1200,0 °C	-150 to +1200 °C
	-238,0 to +2192,0 °F	-238 to +2192 °F
Thermocouple T	-200,0 to +400,0 °C	-200 to +400 °C
	-328,0 to +752,0 °F	-328 to +752 °F
Thermocouple N	-150,0 to +1300,0 °C	-150 to +1300 °C
	-238,0 to +2372,0 °F	-238 to +2372 °F

The thermocouple software menu allows selection among several types of thermocouples, temperature units (Celsius or Fahrenheit), resolution (degree or tenth of degrees) and a display offset. Offset value is programmed if we know that a difference may exist between the temperature under measurement and the temperature read by the sensor. This difference can be corrected by programming an offset from -19.9 to +99.9.

LED TARE will light up each time that an offset value is programmed.

Example:

In a process of temperature control the thermocouple sensor is located in a part of the process where temperature is 5 degrees below than in the point in where the control has to be done. By programming an offset of 5 points, with 1 degree resolution, the deviation will be corrected.

Configurable parameters for this input are:

- g) Thermocouple type [J, K, T, N].
- h) Reading units in degree Celsius "°C" or Fahrenheit "°F".
- i) Resolution in tenth of degrees "0,1°" or in whole degrees "1°".
- j) Offset. The instrument comes from factory with offset=0

After introducing these parameters, the display range and linearization for the selected thermocouple input are adjusted automatically.

THERMOCOUPLE (J, K, T, N) INPUT WIRING

Instrument's rear view

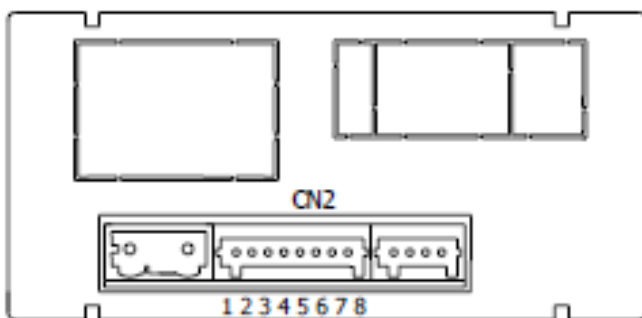

Thermocouple type J, K, T, N

INPUT SIGNAL CONNECTOR

CN2

- PIN 1 = No connection
- PIN 2 = No connection
- PIN 3 = No connection
- PIN 4 = No connection
- PIN 6 = No connection
- PIN 7 = +TC
- PIN 8 = - TC

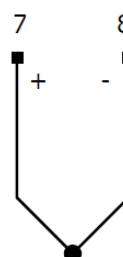

DISPLAY CONFIGURATION by KEYBOARD

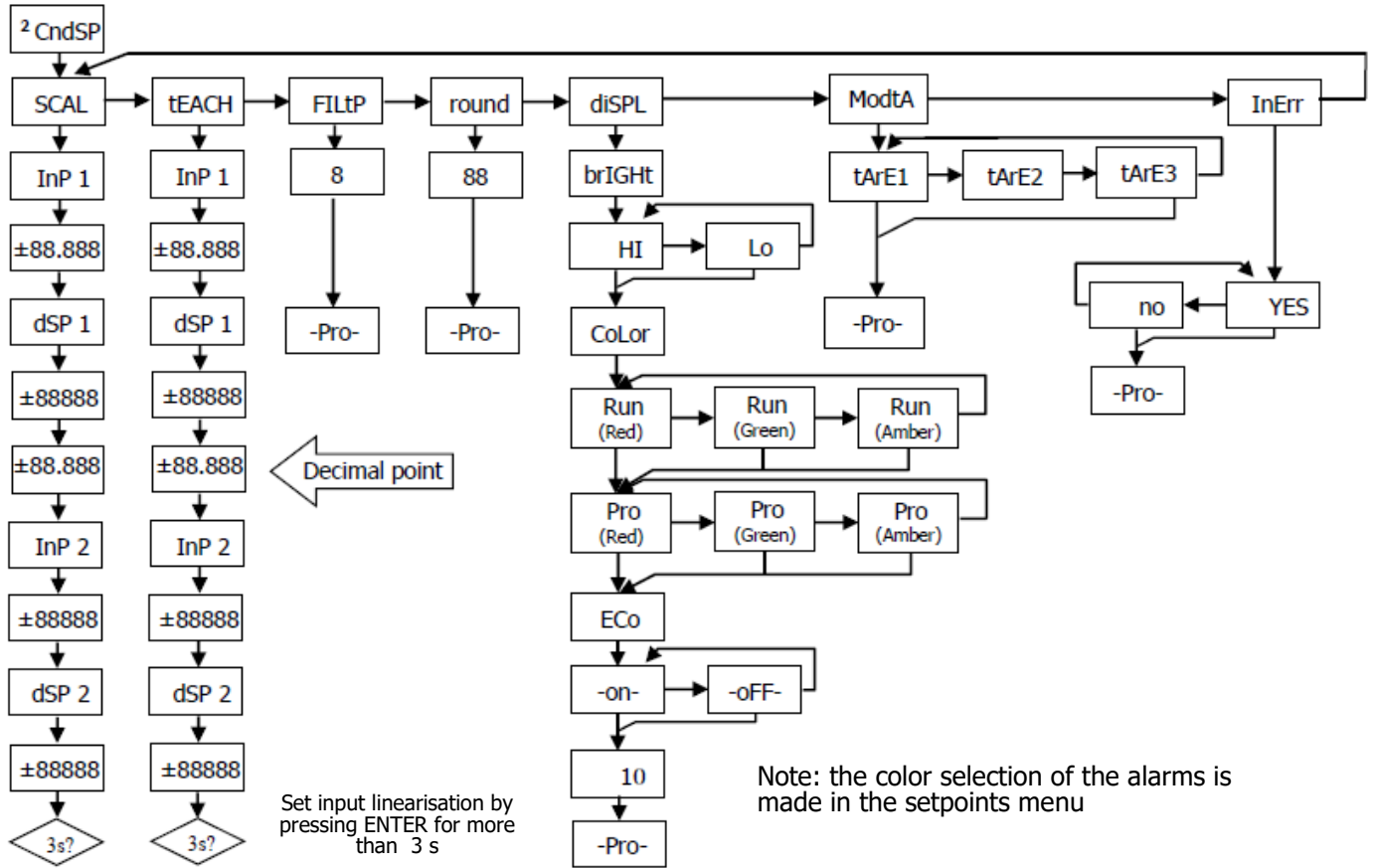

Note: the color selection of the alarms is made in the setpoints menu

ENGLISH

SCALING

It is only necessary to scale the meter when it has been configured for **process o load cell**. Scaling consist of assigning a display value to each input signal value.

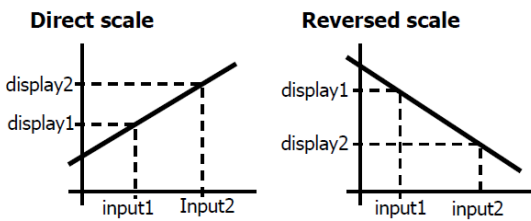

In linear processes it is achieved by programming two coordinates (input1, display1) and (input2, display2), between which is established a linear relation where to each input signal value corresponds a display value.

The relationship can be direct or reversed. In order to obtain more accuracy, points 1 and 2 should be located approximately at both extremes of the process.

In nonlinear processes it is possible to program up to 11 points input-display. Each two points are connected by a straight line and the whole is a curve that represents the relationship between the input value and the display value.

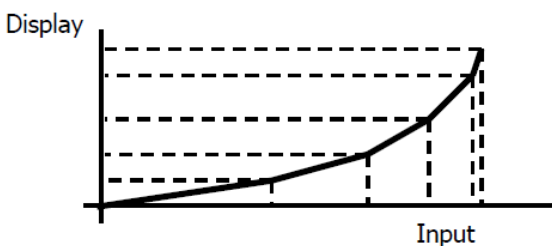

In order to obtain more accuracy in the measuring it is recommended to program the highest possible number of points and reduce the segment length.

Input values must always be programmed in an increasing or decreasing order. Avoid assigning two different display values to two equals input values.

Display values can be entered in any order and even be repeated for different inputs.

Below the first point programmed, the relationship established between the two first points of the scale is followed. Above the last point programmed, the relationship established between the two last points of the scale is followed.

SCALE PROGRAMMING by KEYBOARD

There are two methods for programming the scale, the **SCAL** method and the **tEACH** method. In the following diagram the SCAL menu has been developed as an example, it is exactly the same menu than the tEACH menu.

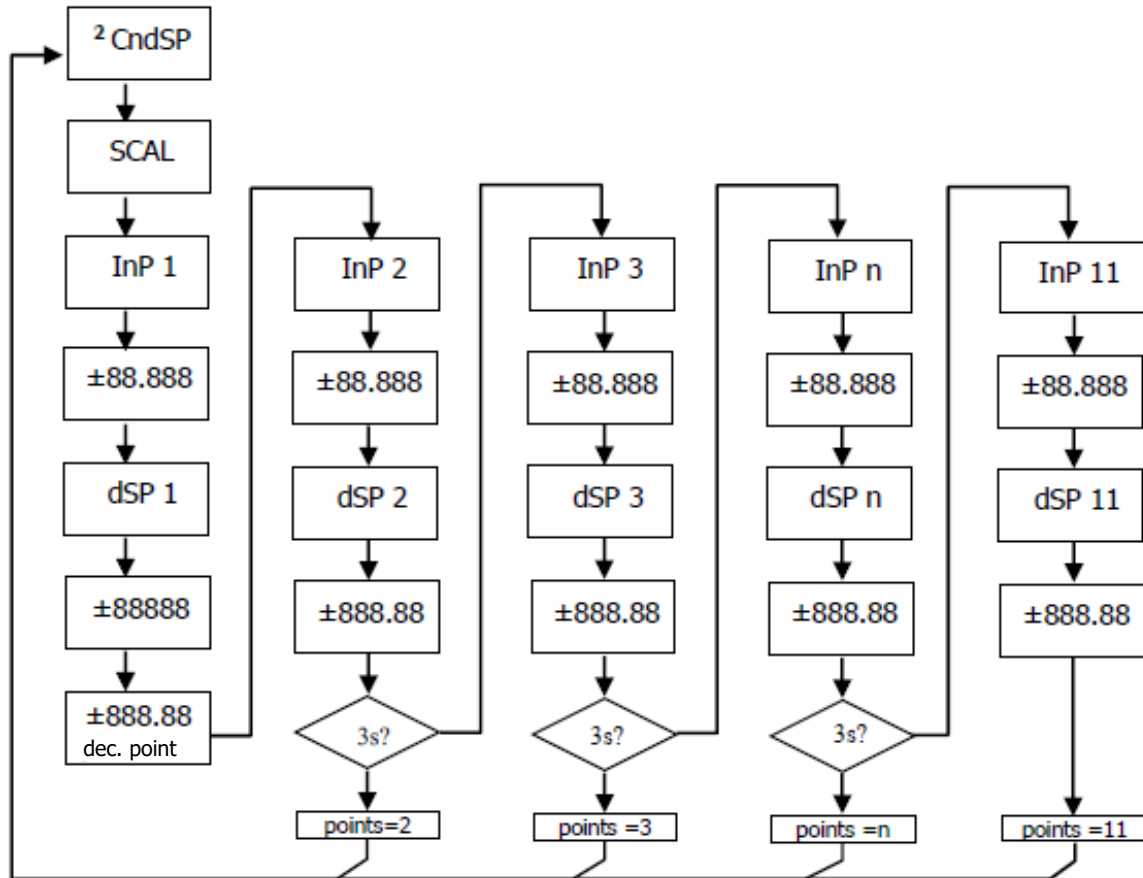

SCAL method

The input and display values are programmed manually. This method can be used when the value of the signal supplied by the transducer at each point of the process is known.

tEACH method

The input values are introduced directly from the signal present in the input connector when each point is programmed. The display values are programmed manually.

This method can be used when it is possible to bring the process to the conditions of each one of the points to be programmed.

Programming of the linearization points

You can accede to the first two points input-display by pressing on the key. To accede to the programming of the rest of the points, press on key during approximately 3s from the display value of point 2. From here the progression is achieved by pressing on key. When enough points has been programmed to define the process, press on during 3s from the programming of the last DSP n value, to get out of the scale programming routine. The rest of the points, up to 11, that have not been programmed are omitted from the display calculation.

Input points

-19999 to 99999

Display points

-19999 to 99999

Display decimal point

0 0.0 0.00 0.000 0.0000

Accessible from the SCAL or tEACH menu, following the first display point. Once acceded to it , it will start to blink in its present

position and through the key will be able to shift to another position.

Moreover it will also affect, as well as the display points, the setpoints value and the value of the analog output scale, in case the corresponding option has been installed.

Filter P
0 to 9
Filter of ponderated average. The value will be modified through the  key. This parameter will set in reverse order the cut-off frequency of the low pass filter, getting the filter deactivated for 0 value. **Not available when the instrument is configured for temperature measurement.**

Round
01 05 10
Will take each one of the values by pressing successively on the  key. with 01 there will be no round, 05 will round the display value at 0 o 5, and with 10 will round at 0 o 10. Just like the previous variable **not available when the instrument is configured for temperature measurement.**



Brightness
Hi Lo
Display brightness level selection.
Hi: high brightness
Lo: low brightness
Display color selection between green, red or amber is possible for both **RUN** and **PRO** modes.



Eco
on off
Allows choosing an operative mode with an up to **45% of ENERGY SAVING***
on: After a programmable time without pressing any key, display will turn off leaving only the right decimal point flashing; all functions remain active. Display will be again active after pressing any key.
off: Deactivates the function.
**Measured at 230V AC power supply, display 100.00, amber colour and with no options.*

Input Error
YES: If input signal is lower than the minimum, display will show "- - - -".
No: Without indication.
(For more information see specifications on page)

Tare Mode
By pressing  key, we can select the mode in which the instrument will treat the process to tare. Each time you accede this menu, the tare value stored in the instrument memory will reset, and as usual when the instrument is in this state, the TARE led will stay off. Once selected the operation mode, we go to the "RUN" mode, from where will be made the tare process.

TArE 1
In mode tArE1 the instrument, pressing on the  key, stores the current displayed value unless it is over scaled, the TARE Led will light up and from this moment the value displayed is the net value, i.e., the measured value minus the value stored in the tare. If having the instrument a tare, we press one more time on the same key, the value displayed at this moment will add up to the tare previously stored, the addition of both will make the resulting tare. By pressing this key during 3s., the instrument will set the tare value to zero, and the TARE led will stop light up, indicating the GROSS value.

TArE 2
In this mode, the  key has no effect. The tare value is now introduced manually, being however the instrument operation the same as in the previous mode. The edit menu Hill be accessed from the "RUN" mode, by pressing on the  key during 3s. Following the diagram.

TArE 3
In this mode, a variable, that we will call net value will be edited, acceding now also from "RUN", after pressing on  during 3 s following the diagram. The tare action, as in the first case, will have no effect until we press on the  key, being the instrument in "RUN" mode, the Led TARE will be then activated. The value stored in tare is now the difference between the value measured by the instrument when the tare action occurred and the net value. The value resulting from the difference between the measured value and the tare value will be the same. It will be necessary to enter in the programming menu and pass by "CndSP" > "ModtA" to reset the tare.

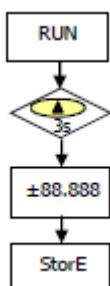

Example:
A process using a liquid contained in a tank from which are known according to the manufacturer specifications the gross weight, 100 Kg, and the net weight 75 Kg. In the weighing process is used a load cell connected to a Micra M instrument and we need to know the liquid net weigh in each instant of the process. By selecting this tare mode, the net value would be introduced via edition following the enclosed diagram. When the instrument is measuring the tank, totally full of liquid, this would be 100 Kg, the instrument is tared, indicating then 75 Kg, and the quantity of remaining liquid in the tank while it is getting emptied.

KEYBOARD FUNCTIONS

Several functions can be controlled via keyboard that will produce different actions depending on the instrument operating mode:

Mode -RUN-:

TARE and RESET TARE functions

Explained in the previous paragraph.

MAX/MIN function

Activated after pressing on the key. From the normal reading mode, a press shows the maximum value read by the instrument since the last time it has been switched on, unless a RESET MAX/MIN is done, the MAX led will light up. A second press shows the minimum value in the same conditions as before, with the consequent minimum indication through the MIN led. A third press bring the instrument back to the normal reading mode.

Function RESET MAX/MIN

Pressing continuously the during 3s., while the instrument shows the peak value (MAX), will produce a reset of the value. Will reset the minimum value if the same action is done while the instrument shows the valley value (MIN).

ENTER 3s function (PROGRAMMING LOCKOUT)

In mode RUN if the ENTER key is pressed continuously during 3 seconds, the instrument will show the indication Code, and following 0000, allowing the user to introduce the security code. If the code that has been introduced is wrong, the instrument will go back to RUN mode, if it is correct, it will allow the access to the security menu. See paragraph 6 Page 34.

ENTER function

One press on the key will bring the instrument to the -Prog- mode.

Mode -Prog-:

KEY 3s (RETURN TO FACTORY PROGRAMMING)

Allows entering a code of access to the reset of the configuration parameters, this code is 74. When entering this code the instrument shows the Loading default Configuration legend, following Store, which means that they have been stored in the non volatile memory of the instrument.

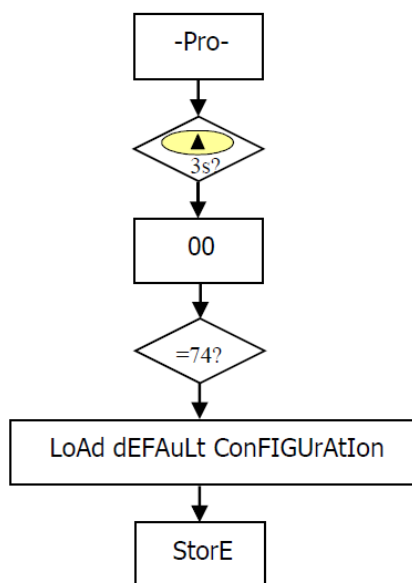

Factory configuration
 INPUT: Process 0 - 10V
 DISPLAY
 Input 1: +00.000 Display 1: +00.000
 Input 2: +10.000 Display 2: +10.000
 Filter P: 0
 Round 01
 Tare mode: 1
 Brightness: High
 DISPLAY COLORS Run Mode: Green, Prog Mode.: Amber
 SETPOINTS
 Setpoint 1: +01.000, Setpoint 2: +02.000
 Setpoint 3: +03.000, Setpoint 4: +04.000
 Compared with: Net
 Mode: HI
 Dly: 00.0
 Alarm Color: No Change
 ANALOG OUTPUT CONFIGURATION
 Display HI: +10.000
 Display LO: +00.000
 LOGIC FUNCTIONS PIN 2=function 1, PIN 3=function 2 and
 PIN 4=function 6

DIRECT ACCESS TO SETPOINTS – KEY

Now, in case any of the **2RE, 4RE, 4OP, 4OPP** options has been installed, the instrument allows a direct access to the programming of the setpoints value, pressing the key sequentially for each one of the setpoints values available according the option installed.

CONNECTOR FUNCTIONS

The connector CN3 provides 3 optocoupled inputs that can be operated from contacts logic levels supplied by an external electronic system. Three different functions may be then added to the functions available from the front panel keys. Each function is associated to a pin (PIN 2, PIN 3 y PIN 4) that is activated applying a low level, in each one, with respect to PIN 1 or COMMON. The association is achieved through the programming of a number between 0 and 15 corresponding to one of the functions listed in the following table.

• **Factory configuration**

As shipped from the factory, the CN3 connector allows the TARE, RESET TARE functions operated from the front-panel keyboard and moreover incorporates the HOLD function. When a HOLD is made, the display value remains frozen while the corresponding pin is activated. The HOLD state, affects neither the instrument internal operation nor the analog and setpoint outputs.

CN3: FACTORY CONFIGURATION

PIN (INPUT)	Function	Number
PIN 1	COMMON	
PIN 2 (INP-1)	TARE	Function nº 1
PIN 3 (INP-2)	RESET TARE	Function nº 2
PIN 4 (INP-3)	HOLD	Function nº 6

Logic functions diagram

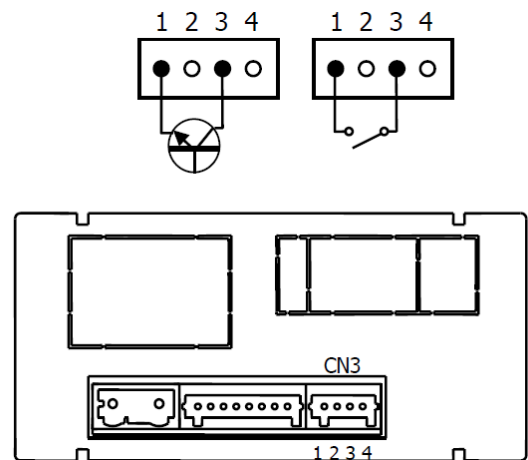

The external electronics applied to the CN3 connector inputs must be capable of withstanding a potential of 40 V/ 20 mA present at all terminals with respect to COMMON. In order to guarantee the electromagnetic compatibility please refer to wiring guidelines.

ENGLISH

LOGIC FUNCTIONS DIAGRAM

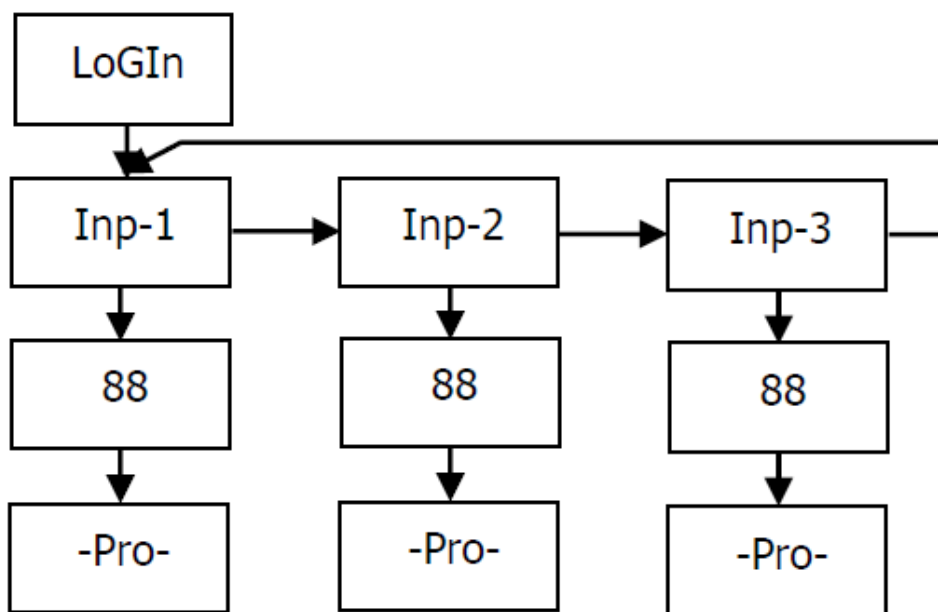

TABLE OF PROGRAMMABLE FUNCTIONS

- **Nº:** Number to select the function by software.
- **Function:** Function name.
- **Description:** Description and characteristics of the function.
- **Activation by:**

Falling edge: the function is activated applying a falling edge to the corresponding pin with respect to common.
 Low level: the function will remain activated as long as the corresponding pin is held at a low level.

Nº	Function	Description	Activation by
0	Deactivated	None	None
1	TARE *	Adds the current display value to the tare memory and sets the display to zero.	Falling edge
2	TARE RESET *	Adds the tare memory to the display value and clears the tare memory.	Falling edge
3	LIST RESET	Performs a reset of the peak or the valley, depending on selection.	Falling edge
4	SEE LIST	Displays peak value (MAX.), valley value (MIN.), tare value (TARE) or gross value (GROSS) depending on selection.	Low level
5	PRINT LIST	Sends to the printer depending on selection MAX., MIN, TARE, SET1, SET2, SET3 or SET4 value.	Falling edge
6	HOLD	Freezes the display while all the outputs remain active	Low level
7	BRIGHTNESS	Changes the display brightness from Hi to Low	Low level
8	DISPLAY COLOR	Changes display color (green, red or amber)	Low level
9	SETP PROG/TARE	Configures Setpoints or Tare depending on Selection List (TARE, SET1, SET2, SET3 and SET4)	Falling edge
10	FALSE SETPOINTS	Simulates that the instrument has a four Setpoints option installed	Low level
11	KEYB. EMULATION	Emulates keyboard (Input 1=ENTER, Input 2=SHIFT, Input 3=UP)	Low level
12	RESERVED		

* Only with mode TARE 1 and TARE 3

LOGIC FUNCTIONS PROGRAMMING

0 to 12

Once the user has acceded the menu of logic functions configuration, he can select, by pressing the  key, a function among those of the table.

*Example: **MICRA-M MAX** with NET value of 1234.5
 Message in Hexadecimal sent from the **MICRA-M MAX** RS4 output when logic function 5 is activated.
 The chain of characters is: "#", "01", 0x0D, "NET: +1234.5", 0x0D
 The **MICRA-M MAX** has to be programmed to work under protocol ASCII.*

Example ticket without date using a panel printer

#01
NET: +1234.5

LOCK OUT PROGRAMMING by KEYBOARD

The instrument is delivered with the programming locked out, giving access to all the programming levels. Once completed the instrument programming we recommend the following security measures be taken:

- Lock out the programming access to prevent from programmed parameters modifications.
- Lock out keyboard functions to prevent from accidental modifications.
- There are two lockout modes: selective and total. If the parameters are going to be readjusted frequently, make a selective lockout. If no adjustment is going to be made, make a total lockout. Keyboard functions lockout is always possible.
- The access to the lockout routine is allowed by entering a personalised code. We recommend changing the code set at factory and to write down your personalised code and keep it in a safe place.

TOTAL LOCKOUT

The access to the programming routines to read data is allowed even if all parameters are locked out totLC=1, but **it won't be possible to enter or modify data**. In this case, when entering in the programming mode, the display shows the indication "-dAtA-".

PARTIAL LOCKOUT

When only some parameters are locked out, all configuration data can be read but **only non protected parameters can be modified**. In such case, when entering in the programming mode, the display shows the indication "-Pro-".

Menus or submenus that can be locked out are:

- Setpoint 1 configuration (SEt 1).
- Setpoint 2 configuration (SEt 2).
- Setpoint 3 configuration (SEt 3).
- Setpoint 4 configuration (SEt 4).
- Input configuration (InPut).
- Display (diSP).
- Display color (CoLor).
- Setpoints value (SPVAL)
- Serial output (rSout) or Ethernet output (EtnEt) configuration
- Analog output configuration (Anout).
- Logic inputs configuration (LoGIn).
- Programming of the key TARE (tArE).
- Direct access to MAX and MIN values (MAHMn).

The first four and "SETVAL" only appear if the corresponding option 2RE, 4RE, 4OP ó 4OPP has been installed, "diSP", "FiltP" and "tARE" do not appear when the instruments configured for temperature measurement. "Anout" will appear when any of the NMA or NMV options are installed, "rSout" when any of the RS2 or RS4 and "EtnEt" for ETH output options are installed.

SECURITY MENU DIAGRAM

The following figure shows the security menu. In this menu is configured the programming lockout. The access to this menu is accomplished from the run mode by pressing the  key during 3 seconds, until the "CodE" indication appears.

The instrument is shipped from factory with the following default code: "0000". Once entered this code, the "LIST" indication will appear, from which we will enter in the parameters lockout. Accessing to the "CHAnG" menu will allow us to enter a personal code, that we have to write down and keep in a safe place.

This personal code makes the default code useless.

If an incorrect code is entered, the instrument will return automatically to the run mode.

Total lockout programming is achieved changing to 1 the "totLC" variable, changing it to 0, will lead to the selective lockout of the programming variables. Programming each one of the parameters to 1 will active the lockout, if they are set to 0 programming will be accessible. Though the programming is locked out, it remains possible to visualise the current programming.

The "StorE" indication informs that the modifications effectuated have been stored correctly.

SECURITY MENU DIAGRAM

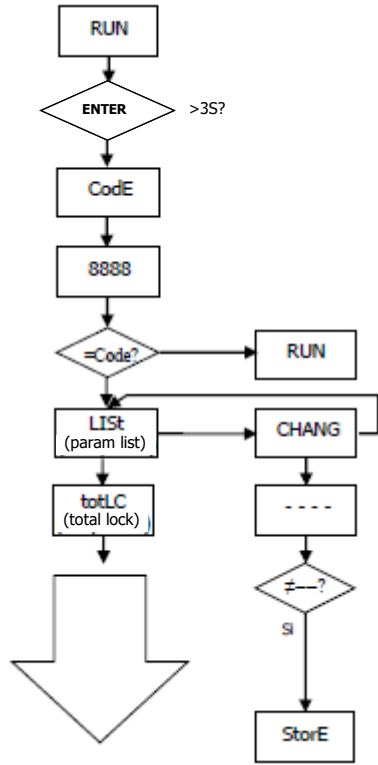

0 allows its programming
1 locks the access to programming
*** Only appear if the corresponding options have been installed**

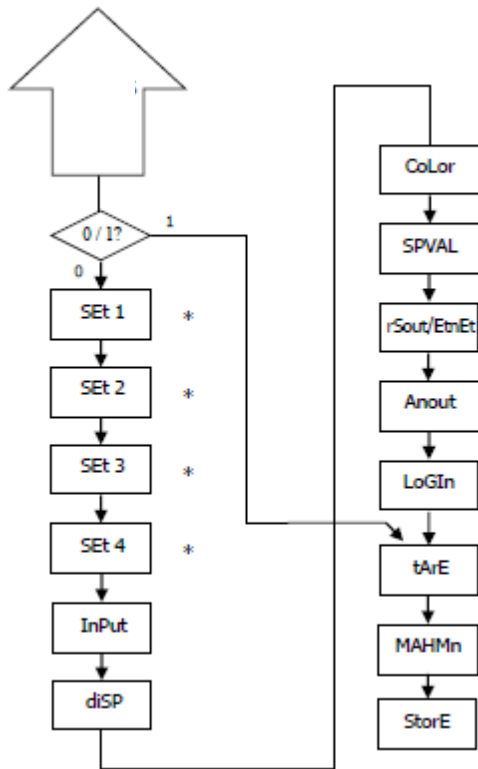

ENGLISH

OUTPUT OPTIONS

Optionally, model **MICRA-M MAX** can incorporate one or several output options for control or communication:

Communication options

- RS2** Serial RS232C
- RS4** Serial RS485
- ETH** Ethernet (included in basic model)

Control options

- NMA** Analog 4-20 mA
- NMV** Analog 0-10 V
- 2RE** 2 Relays SPDT 8A
- 4RE** 4 Relays SPST 5A
- 4OP** 4 NPN outputs
- 4OPP** 4 PNP outputs

All mentioned options are optoisolated with respect to input signal and power supply. The output cards are easily installed on the meter's main board by means of plug-in connectors and each one activates its own programming modules that provides complete software configuration. Additional capabilities of the unit with output options:

- Control and processing of limit values via ON/OFF logic outputs (2 relays, 4 relays, 4 NPN outputs or 4 PNP outputs) or proportional output (4-20mA, 0-10V).
- Communication, data transmission and remote programming via serial interface.

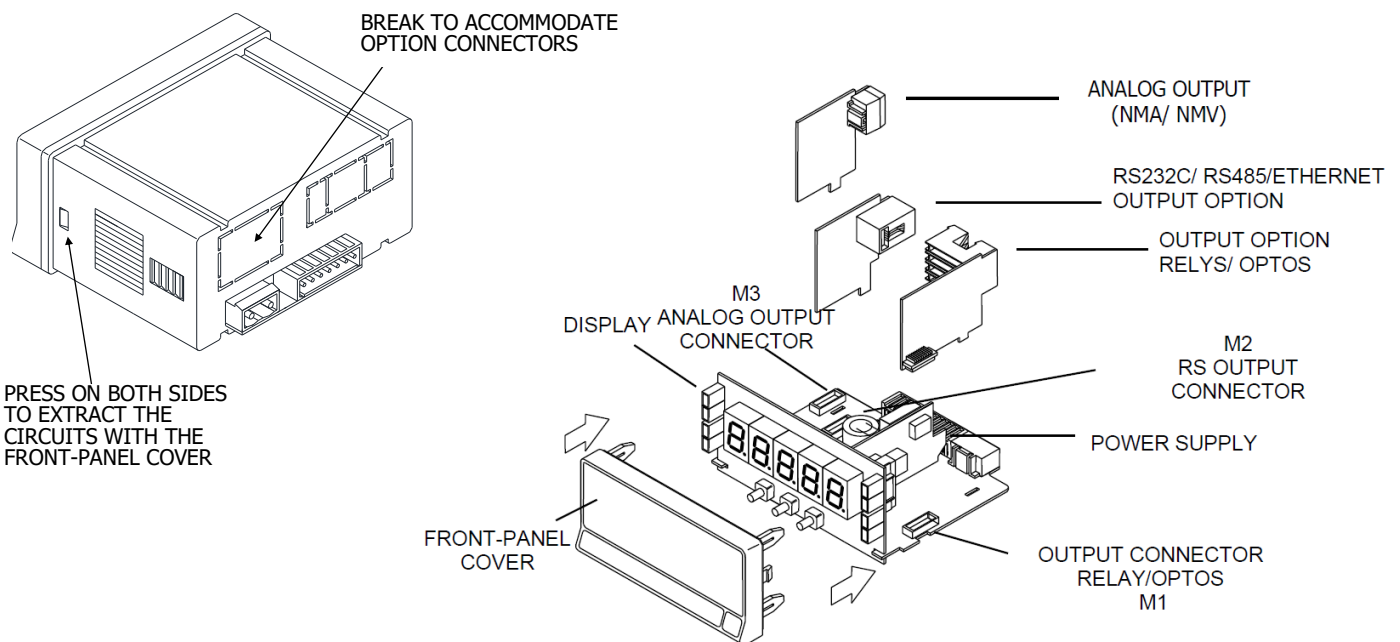

The **2RE**, **4RE**, **4OP** y **4OPP** options are alternative and only one of them can be placed into the connector M1.

The **RS2**, **RS4** and **ETH** options are also alternative and only one of them can be placed into the connector M2

The **NMA** or **NMV** option is placed into the connector M3.

Up to three output options can be present at the same time and operate simultaneously:

- One analog (ref. **NMA** or ref **NMV**)
- One RS232C (ref. **RS2**), RS485 (ref. **RS4**) or Ethernet (ref. **ETH**).
- One 2 relays (ref. **2RE**) or 4 relays (ref. **4RE**) or 4 NPN (ref. **4OP**) or 4 PNP (ref. **4OPP**) outputs.

SETPOINTS OUTPUTS

Introduction

An option of 2 or 4 SETPOINTS, programmable within the full display range, can be incorporated to the unit thus providing alarm and control capabilities by means of individual LED indicators and relay or transistor outputs. All the setpoints provide independently programmable value, time delay (in seconds), asymmetrical or symmetrical hysteresis (in counts of display) and selectable HI/LO acting.

The setpoint option consists of a plug-in additional card that once installed to the meter's main board, activates its own programming module, they are totally configurable by the user and their access can be locked out via software.

These are the control output options available:

- 2RE:** 2 Relays SPDT 8A
- 4RE:** 4 Relays SPST 5A
- 4OP:** 4 NPN outputs
- 4OPP:** 4 PNP outputs

These types of outputs, capable of carrying out a wide variety of control operations and processing of limit values, increases notably the unit's performance qualities thanks to the possibility of combining basic alarm functions with advanced safety and control applications.

Description of operation

As programmed like independent setpoints, the alarm outputs activate when the display value reaches the user-programmed value. The independent alarms programming requires definition of the following basic parameters:

a. COMPARISON NET/ GROSS

In "NET" mode will compare the setpoint value with the display net value. In "GROSS" mode, the comparison will be with the sum net + tare.

b. HI/ LO ACTING MODE.

In HI mode, the output activates when the display value exceeds the setpoint level and in LO mode, the output activates when the display value falls below the setpoint

c. RELAYS CONTACT DEFAULT STATE NO/NC.

Defines relays contact status by default: "NO" (normal open) or "NC" (normally closed). NC status can be used as a **FAIL SAFE** function, allowing the power supply or device failure detection sending a signal informing to the PLC or main monitoring system.

d. PROGRAMMABLE TIME DELAY or HYSTERESIS.

Each output action can be deferred by a programmable time delay or hysteresis level.

The time delay is the time that takes the output to activate after passing through the setpoint in the up or down direction, while the hysteresis band will be selected asymmetrical i.e. only acts on the output deactivation edge.

The delay is programmable in seconds, from 0 to 99.

The hysteresis can be programmed, in counts, within the full display range. The decimal point appears in the same position as programmed in the display configuration module.

The figures 1 and 2 show the time delay action (dly) and the asymmetrical hysteresis action (hys-1) of two alarms (SET1 and SET2) programmed to activate in HI mode (OUT1) and LO mode (OUT2)

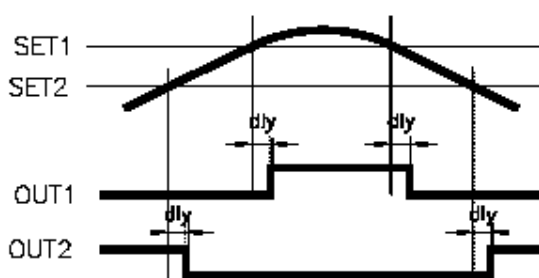

Delay action

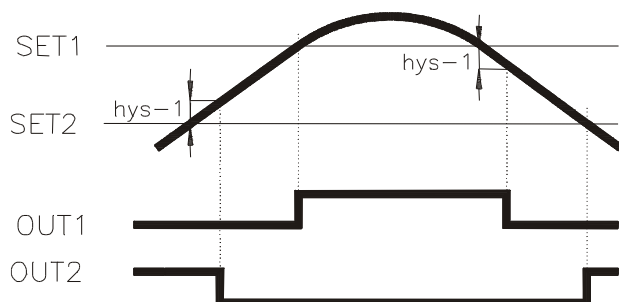

Asymmetrical hysteresis

ENGLISH

INSTALLATION

Lift out the electronics assembly from the case and use a screw-driver to push on the junctions between the case and the shadow areas to detach them from the case. See fig. The so performed orifice will allow any of the set-points (2RE, 4RE, 4OP or 4OPP) board output connectors be brought out at the rear of the instrument. The option is installed by plugging the connector in the main board location. Insert the card pin in the corresponding main board slot and push down to attach both connectors.

If the instrument is to be installed in high vibrating environments, it is recommended to solder the card to the main board making use of the copper tracks on both sides of the card pin and around the main board hole on its solder side.

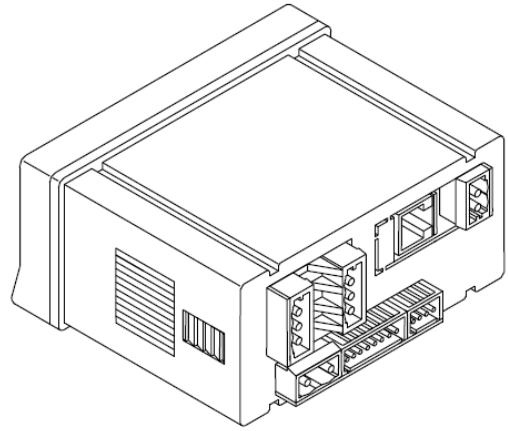

WIRING

2RE - 2 RELAYS OPTION

PIN 4 = NO2	PIN 1 = NO1
PIN 5 = COMM2	PIN 2 = COMM1
PIN 6 = NC2	PIN 3 = NC1

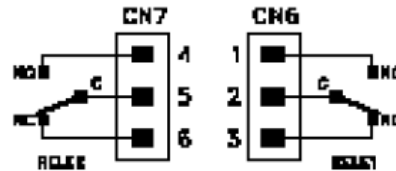

4RE - 4 RELAYS OPTION

PIN 4 = RL4	PIN 1 = RL1
PIN 5 = N/C	PIN 2 = RL2
PIN 6 = COMM	PIN 3 = RL3

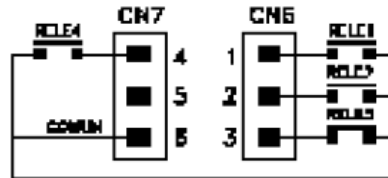

4OP - 4 OPTOS NPN OPTION

PIN 4 = OP4	PIN 1 = OP1
PIN 5 = N/C	PIN 2 = OP2
PIN 6 = COMM	PIN 3 = OP3

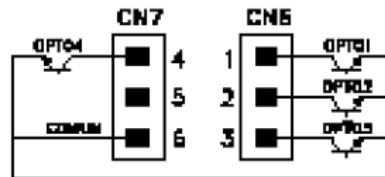

4OPP - 4 OPTOS PNP OPTION

PIN 4 = OP4	PIN 1 = OP1
PIN 5 = N/C	PIN 2 = OP2
PIN 6 = COMM	PIN 3 = OP3

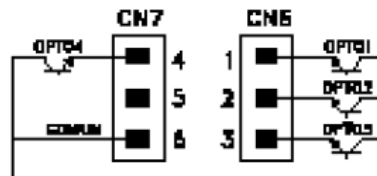

Each output card is supplied with an adhesive label that indicates the wiring connections of each option. To help identifying each terminal, this label should be placed in the lower side of the meter case, beside the basic functions label.

NOTE: In case that the outputs are used to drive inductive loads, it is recommended to add an RC network between the coil terminals (preferably) or between the relay contacts to limit electromagnetic effects.

SETPOINTS TECHNICAL SPECIFICATIONS

CHARACTERISTICS

MAX. CURRENT (RESISTIVE LOAD)
 MAX. POWER
 MAX. VOLTAGE
 CONTACT RESISTANCE
 SWITCHING TIME Máx.

2RE OPTION

8 A
 2000 VA / 192 W
 250 VAC / 150 VDC
 Máx. 3mΩ
 10ms

4RE OPTION

5 A
 1250 VA / 150 W
 277 VAC / 125 VDC
 Máx. 30mΩ
 Máx. 10ms

4OP & 4OPP OPTIONS

MAX. VOLTAGE 50 VDC
 MAX. CURRENT 50 mA
 LEAKAGE CURRENT 100 μA (máx.)
 SWITCHING TIME 1 ms (máx.)

SETPOINTS MENU DIAGRAM by KEYBOARD

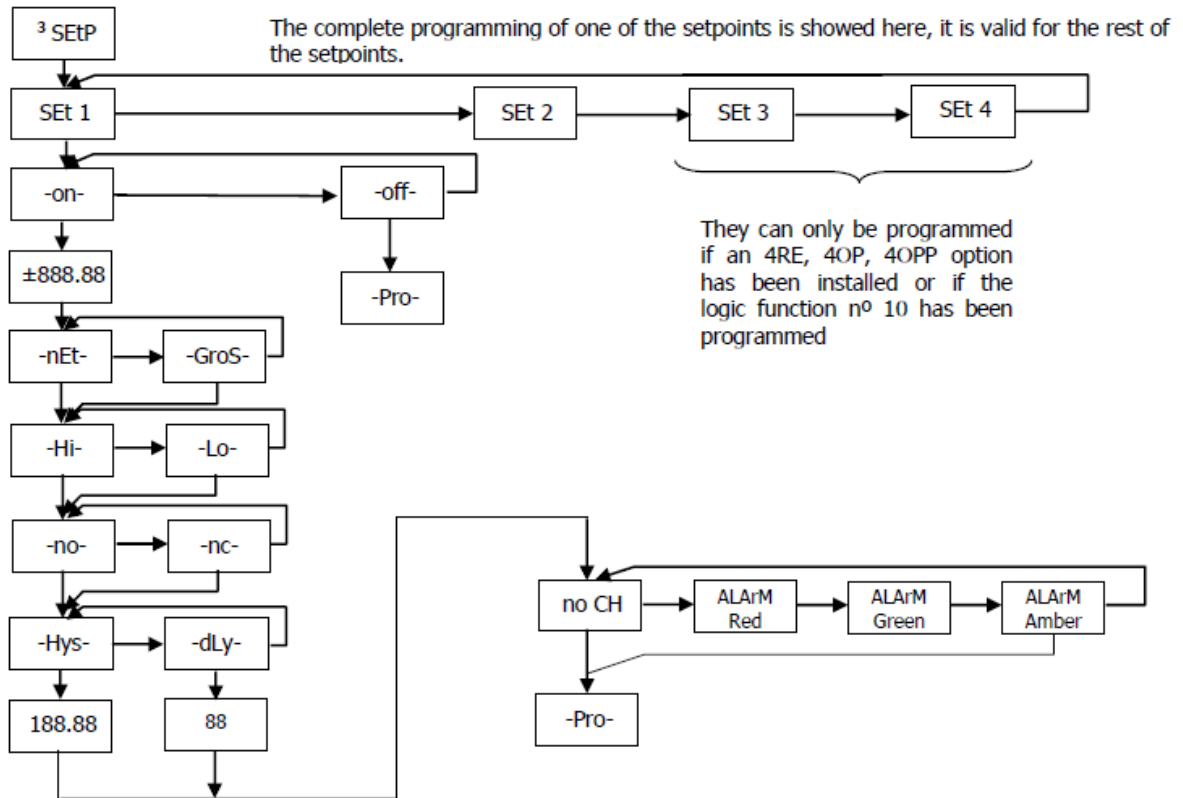

ENGLISH

DIRECT ACCES TO THE SETPOINT PROGRAMMING

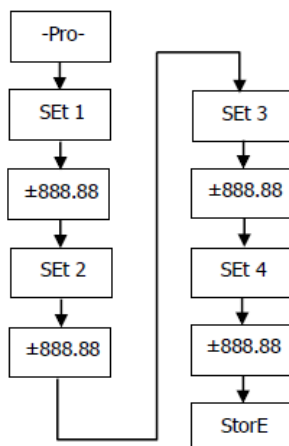

If any of the options corresponding to the setpoints has been installed, it is possible to accede directly to the setpoints value without need to go through the programming menu just by pressing

the key in PROG mode, as shown in diagram below, supposing that the card installed are 4RE, 4OP or 4OPP, if it is the 2RE card only Set1 y Set2 would appear.

Setpoints configured at "off" do not appear on the list".

Remember that the decimal point position comes determined by what has been programmed in the SCAL menu.

RS2 / RS4 OUTPUT OPTIONS by KEYBOARD

Introduction

The RS232C output option consists of an additional card (reference **RS2**) that is installed in the M2 plug-in connector of the instrument's main board. The card incorporates one 4 wires telephone socket with output at the rear of the instrument.

The RS485 output option consists of an additional card (reference **RS4**) that is also installed in the M2 plug-in connector of the instrument's main board. The card incorporates a 6-pin / 4-contact telephone socket with output at the rear of the meter.

The serial output permits to construct a communication line through which a master device can request the transmission of data such de display value, setpoint values, peak, valley, tare (or offset in case of thermometers) and to perform operations such as tare of the display, reset of the peak, valley or tare memories and update setpoint values..

The output option is totally software configurable as for the transmission rate (1200, 2400, 4800, 9600 ó 19200 Baud), the instrument's address (from 00 to 99), the protocol (ASCII, ISO 1745 and MODBUS RTU).

The operating mode is half-duplex and it normally stands in data reception mode until reception of a message.

A valid data transmission may cause the immediate execution of an action (tare, reset of peak, valley or tare memories modification of setpoint values) or the transmission of a response from the instrument (display value, one of the setpoints value, peak, valley, tare / offset). Only the display value can be called up via external contact.

Three communication modes are available; the ASCII mode uses a simple protocol compatible with several DITEL instruments. The ISO mode, in accordance with the ISO 1745 norm, allows a more effective communication in noisy environments as it checks the messages validity checking both transmission and reception. And eventually the protocol MODBUS RTU

As you will see in the functions table, the protocol ASCII uses 1 or 2 bytes according to the command type and the protocol ISO 1745 imposes the use of two bytes per command.

ENGLISH

RS OUTPUT MENU DIAGRAM

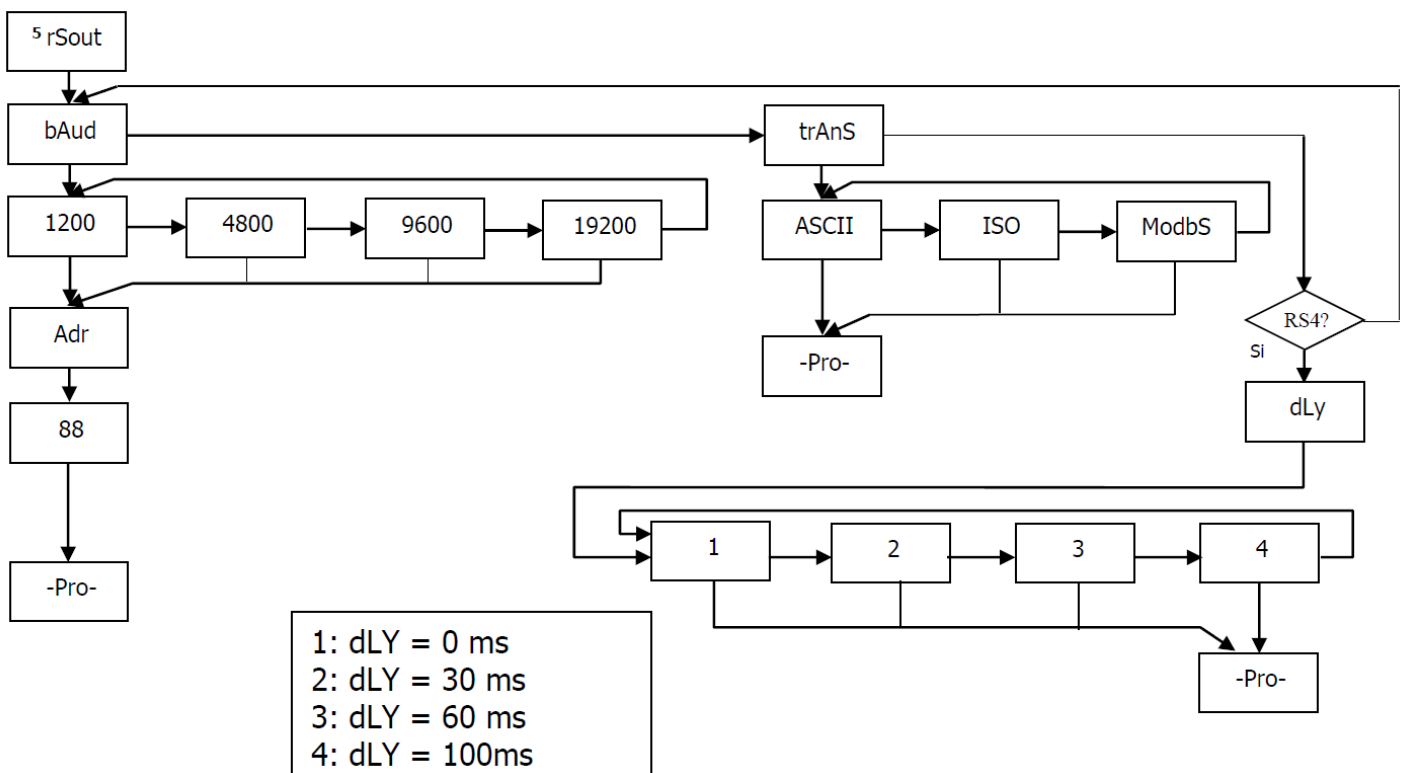

ETHERNET OUTPUT CONFIGURATION by KEYBOARD

Compatible with most commonly used Ethernet standards; 100BASE-T and 10BASE-T which are automatically detected or transmission mode, full-duplex or half-duplex.

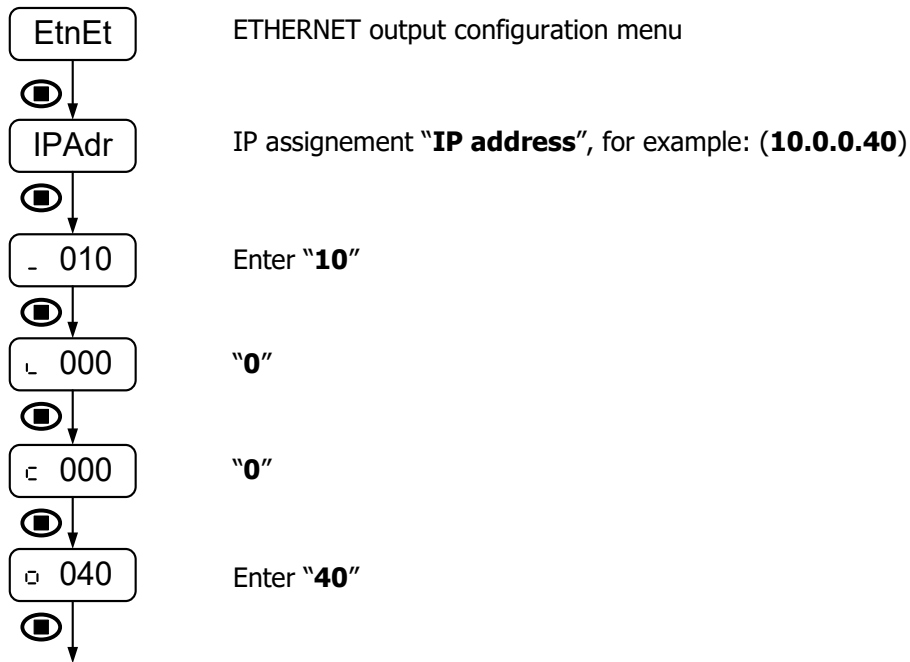

ENGLISH

ETH WIRING

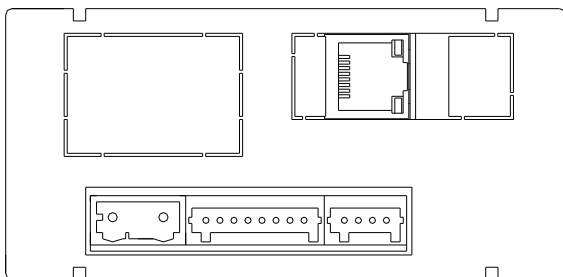

CN5: RJ45 100BASE-T / 10BASE-T		
PIN	NAME	DESCRIPTION
1	+Tx	+ Data transmission
2	-Tx	- Data transmission
3	+Rx	+ Data reception
6	-Rx	- Data reception

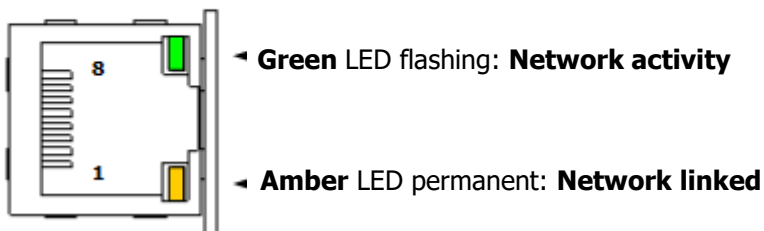

ASCII PROTOCOL

The Transmission format is: 1 START bit, 8 DATA bits, NO parity bit and 1 STOP bit.

• MESSAGE FORMAT TO BE SENT

A message sent to the instrument must be composed of the following sequence of ASCII characters:

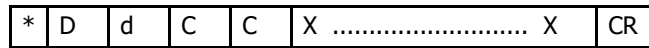

One " * " byte [ASCII 42] of start of message.

Two address bytes (from 00 to 99).

One or two ASCII characters corresponding to the desired command according to the functions table (List of commands).

In case that the command request for a modification of parameters, the new value shall be transmitted with one byte of sign (+ [ASCII 43] or - [ASCII 45]) followed by a block of N ASCII characters (depending on model), including the decimal point.

One " CR " [ASCII 13] character of end of message. CR= Carriage Return

• MESSAGE FORMAT FROM INSTRUMENT

The data sent from the instrument as a response to a data request type command from the master device is the following:

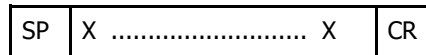

One byte of blank space [ASCII 32].

One text (requested values) consisting of a byte of sign (+ [ASCII 43] or - [ASCII 45]) followed by a block of N ASCII characters (depending on model) including the decimal point.

One " CR " byte [ASCII 13] of end of message.

If the command belongs to "orders" or "changing parameters", the instruments gives no response.

ISO 1745 PROTOCOL

The transmission format is: 1 START bit, 7 DATA bits, 1 EVEN PARITY bit and 1 STOP bit.

• MESSAGE FORMAT TO BE SENT

The message format, as sent from the master device, must consist of the following sequence of characters:

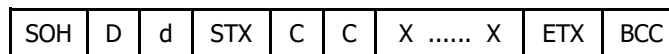

One byte SOH of start of message [ASCII 01].

Two bytes corresponding the first to the tens and the second to the units of the instrument address number.

One byte STX of start of text [ASCII 02].

Two commands bytes according to the functions table.

In case of commands that change parameters, a block of N bytes corresponding to the new value including sign and decimal point.

One byte ETX of end of text [ASCII 03].

One control byte BCC calculated in the following manner:

Perform an exclusive-OR with all bytes between the STX (not included) and the ETX (included).

- If the obtained byte (in ASCII format) is higher than 32, it can be taken as the BCC.
- If the obtained byte (in ASCII format) is lower than 32, the BCC byte will be obtained by adding 32.

• MESSAGE FORMAT FROM INSTRUMENT

The format of a message as sent from the instrument in response to a command from the master device is the following:

1. In case of commands that ask for transmission of a value (data request type):

SOH	D	d	STX	X	X	ETX	BCC
-----	---	---	-----	---------	---	-----	-----

- One byte SOH of start of message [ASCII 01].
- Two address bytes.
- One byte STX of start of text [ASCII 02].
- N bytes corresponding to the requested value (including the sign and decimal point).
- One byte ETX of end of text [ASCII 03].
- One control byte BCC calculated with the method described in page 92.

2. In case of commands that do not imply the return of a value (command type or changing parameter):

D	d	ACK	or	D	d	NAK
---	---	-----	----	---	---	-----

The instrument sends a confirmation when it receives a message.
 If the message has been correctly received and interpreted, the response will consist of two address bytes and one "ACK" [ASCII 06]
 If the received message has not been well interpreted or it has been detected as to have errors, the response will be two address bytes and a "NAK" [ASCII 21].

List of Commands

REQUEST OF DATA

ASCII	ISO	Information
P	0P	Peak value
V	0V	Valley value
T	0T	Tare value
D	0D	Display value
I	0I	Alarm "status" byte
L1	L1	Setpoint 1 value
L2	L2	Setpoint 2 value
L3	L3	Setpoint 3 value
L4	L4	Setpoint 4 value
	NB	Cards installed Returns: "04": RS2 "05": RS2, 2RE "06": RS2, 4OP "08": RS4 "09": RS4, 2RE "0": RS4, 4 Setpoints(4RE, 4OP ó 4OPP) "44": NMA or NMV, RS2 "45": NMA or NMV, RS2, 2RE "46": NMA or NMV, RS2, 4 Setpoints(4RE, 4OP ó 4OPP) "48": NMA or NMV, RS4 "49": NMA or NMV, RS4, 2RE "4": NMA or NMV, RS4, 4 Setpoints(4RE, 4OP ó 4OPP)
	TT	Model + Version

MODIFICATION OF DATA

<i>ASCII</i>	<i>ISO</i>	<i>Parameter</i>
M1	M1	Change the setpoint1 value without saving in memory
M2	M2	Change the setpoint2 value without saving in memory
M3	M3	Change the setpoint3 value without saving in memory
M4	M4	Change the setpoint4 value without saving in memory
b1	b1	Change brightness to "Hi" level without saving in memory
b2	b2	Change brightness to "Lo" level without saving in memory
c1	c1	Change display color to amber without saving in memory
c2	c2	Change display color to green without saving in memory
c3	c3	Change display color to red without saving in memory

COMMANDS

DITEL	ISO	Command
p	0p	Peak reset
v	0v	Valley reset
r	0r	Tare reset
t	0t	Tare the display

MODBUS – RTU

COMMANDS and MAP ADDRESSES

Commands			
116	"t"	Tare	Add display value to tare memory and set the display to zero. Sample of frame in hexadecimal for unit n° 1 : 01 05 00 74 FF 00 CC 20
114	"r"	Tare Reset	Add the tare value to the display value and clear the tare memory. Sample of frame in hexadecimal for unit n° 1 : 01 05 00 72 FF 00 2C 21
112	"p"	Reset Max	Reset the MAX ("Peak") value. Not saved in memory Sample of frame in hexadecimal for unit n° 1 : 01 05 00 70 FF 00 8D E1
118	"v"	Reset Min	Reset the MIN ("Val") value. Not saved in memory Sample of frame in hexadecimal for unit n° 1 : 01 05 00 76 FF 00 6D E0
98+49	"b1"	Brightness HI	Change the display brightness to HI. Not saved in memory Sample of frame in hexadecimal for unit n° 1 : 01 05 62 31 FF 00 C2 4D
98+50	"b2"	Brightness LO	Change the display brightness to LO. Not saved in memory Sample of frame in hexadecimal for unit n° 1 : 01 05 62 32 FF 00 32 4D
99+49	"c1"	Color Display Orange	Change the color display to Orange. Not saved in memory Sample of frame in hexadecimal for unit n° 1 : 01 05 63 31 FF 00 C3 B1
99+50	"c2"	Color Display Red	Change the color display to Red. Not saved in memory Sample of frame in hexadecimal for unit n° 1 : 01 05 63 32 FF 00 33 B1
99+51	"c3"	Color Display Green	Change the color display to Red. Not saved in memory Sample of frame in hexadecimal for unit n° 1 : 01 05 63 33 FF 00 62 71

Programming Data (Read/Write)			
Word	Byte	Variable	Description
0	0	InputType	0=Process, 1=Load Cell, 2=Temperature
	1	ProcessType	0=10V, 1=20mA
1	2	LoadRange	0=15mV, 1=30mV, 2=150mV
	3	TemplInput	0=Pt100, 1=Thermocouple
2	4	TCType	0=J, 1=K, 2=T, 3=N
	5	TempUnits	0=°C, 1=°F
3	6	TempDecP	0=1°, 1=0.1°
	7	NScalingPoints	2 to 11
4	8	Input 1 [5]	Digit 4
	9		Digit 3
5	10		Digit 2
	11		Digit 1
6	12		Digit 0
	13	Input 2 [5]	Digit 4
7	14		Digit 3
	15		Digit 2
8	16		Digit 1
	17		Digit 0
9	18	Input 3 [5]	Digit 4
	19		Digit 3
10	20		Digit 2
	21		Digit 1
11	22		Digit 0

12	23	Input 4 [5]	Digit 4
	24		Digit 3
	25		Digit 2
13	26		Digit 1
	27		Digit 0
14	28	Input 5 [5]	Digit 4
	29		Digit 3
15	30		Digit 2
	31		Digit 1
16	32		Digit 0
	33	Input 6 [5]	Digit 4
17	34		Digit 3
	35		Digit 2
18	36		Digit 1
	37		Digit 0
19	38	Input 7 [5]	Digit 4
	39		Digit 3
20	40		Digit 2
	41		Digit 1
21	42		Digit 0
	43	Input 8 [5]	Digit 4
22	44		Digit 3
	45		Digit 2
23	46		Digit 1
	47		Digit 0

MODBUS – RTU MAP ADDRESSES

24	48	Input 9 [5]	Digit 4
	49		Digit 3
25	50		Digit 2
	51		Digit 1
26	52		Digit 0
	53	Input 10 [5]	Digit 4
27	54		Digit 3
	55		Digit 2
28	56		Digit 1
	57		Digit 0
29	58	Input 11 [5]	Digit 4
	59		Digit 3
30	60		Digit 2
	61		Digit 1
31	62		Digit 0
	63	Display 1 [5]	Digit 4
32	64		Digit 3
	65		Digit 2
33	66		Digit 1
	67		Digit 0
34	68	Display 2 [5]	Digit 4
	69		Digit 3
35	70		Digit 2
	71		Digit 1
36	72		Digit 0
	73	Display 3 [5]	Digit 4
37	74		Digit 3
	75		Digit 2

38	76		Digit 1
	77		Digit 0
39	78	Display 4 [5]	Digit 4
	79		Digit 3
40	80		Digit 2
	81		Digit 1
41	82		Digit 0
	83	Display 5 [5]	Digit 4
42	84		Digit 3
	85		Digit 2
43	86		Digit 1
	87		Digit 0
44	88	Display 6 [5]	Digit 4
	89		Digit 3
45	90		Digit 2
	91		Digit 1
46	92		Digit 0
	93	Display 7 [5]	Digit 4
47	94		Digit 3
	95		Digit 2
48	96		Digit 1
	97		Digit 0
49	98	Display 8 [5]	Digit 4
	99		Digit 3
50	100		Digit 2
	101		Digit 1
51	102		Digit 0
	103	Display 9 [5]	Digit 4

MODBUS – RTU MAP ADDRESSES

52	104		Digit 3	65	130		Digit 1
	105		Digit 2		131		Digit 0
53	106		Digit 1	66	132	Mode RUN Color	0 =Amber, 1 =Red, 2 =Green
	107		Digit 0		133	Mode PROG Color	0 =Amber, 1 =Red, 2 =Green
54	108		Digit 4	67	134	Brightness	0 =HI, 1 =LO
	109		Digit 3		135	ECO Mode	0 =OFF, 1 =ON
55	110	Display 10 [5]	Digit 2	68	136	ECO Mode Minutes [2] (00 to 99 min)	Digit 1
	111		Digit 1		137		Digit 0
56	112		Digit 0	69	138		Digit 4
	113		Digit 4		139		Digit 3
57	114	Display 11 [5]	Digit 3	70	140	Setpoint 1 Value [5]	Digit 2
	115		Digit 2		141		Digit 1
58	116		Digit 1	71	142		Digit 0
	117		Digit 0		143		Digit 4
59	118	DecimalPoint	0 =99999, 1 =9999.9, 2 =999.99, 3 =99.999, 4 =9.9999	72	144	Setpoint 2 Value [5]	Digit 3
	119		Digit 2		145		Digit 2
60	120	OffsetTemp [3]	Digit 1	73	146		Digit 1
	121		Digit 0		147		Digit 0
61	122	FilterP	0 to 9	74	148		Digit 4
	123	<i>reserved</i>			149		Digit 3
62	124	Round	0 =01, 1 =02, 2 =05, 3 =10	75	150	Setpoint 3 Value [5]	Digit 2
	125	Input Error Limit	0 =NO, 1 =YES		151		Digit 1
63	126	Tare Mode	0 =Tare1, 1 =Tare2, 2 =Tare3	76	152		Digit 0
	127		Digit 4		153		Digit 4
64	128	Tare Set Value [5]	Digit 3	77	154	Setpoint 4 Value [5]	Digit 3
	129		Digit 2		155		Digit 2

MODBUS – RTU MAP ADDRESSES

78	156		Digit 1	92	184	<i>reserved</i>	
	157		Digit 0		185		
79	158	Setpoint 1 Delay/ Hysteresis [5]	Digit 4 (if Hysteresis)	93	186	ON/OFF Setpoint 1	0=OFF, 1=ON
	159		Digit 3 (if Hysteresis)		187	ON/OFF Setpoint 2	0=OFF, 1=ON
80	160		Digit 2 (if Hysteresis)	94	188	ON/OFF Setpoint 3	0=OFF, 1=ON
	161		Digit 1		189	ON/OFF Setpoint 4	0=OFF, 1=ON
81	162		Digit 0	95	190	HI/LO Setpoint 1	0=HI, 1=LO
	163	Digit 4 (if Hysteresis)	191		HI/LO Setpoint 2	0=HI, 1=LO	
82	164	Setpoint 2 Delay/ Hysteresis [5]	Digit 3 (if Hysteresis)	96	192	HI/LO Setpoint 3	0=HI, 1=LO
	165		Digit 2 (if Hysteresis)		193	HI/LO Setpoint 4	0=HI, 1=LO
83	166		Digit 1	97	194	Setpoint 1 Delay / Hysteresis	0=DLY, 1=HYS
	167		Digit 0		195	Setpoint 2 Delay / Hysteresis	0=DLY, 1=HYS
84	168		Setpoint 3 Delay/ Hysteresis [5]	Digit 4 (if Hysteresis)	98	196	Setpoint 3 Delay / Hysteresis
	169	Digit 3 (if Hysteresis)		197		Setpoint 4 Delay / Hysteresis	0=DLY, 1=HYS
85	170	Digit 2 (if Hysteresis)		99	198	NoNc Setpoint 1	0=NO, 1=NC
	171	Digit 1			199	NoNc Setpoint 2	0=NO, 1=NC
86	172	Digit 0		100	200	NoNc Setpoint 3	0=NO, 1=NC
	173	Digit 4 (if Hysteresis)	201		NoNc Setpoint 4	0=NO, 1=NC	
87	174	Setpoint 4 Delay/ Hysteresis [5]	Digit 3 (if Hysteresis)	101	202	Setpoint 1 Comparison Value	0=Net, 1=Gross
	175		Digit 2 (if Hysteresis)		203	Setpoint 2 Comparison Value	0=Net, 1=Gross
88	176		Digit 1				
	177		Digit 0				
89	178		<i>reserved</i>				
	179						
90	180	<i>reserved</i>					
	181						
91	182	<i>reserved</i>					
	183						

MODBUS – RTU MAP ADDRESSES

102	204	Setpoint 3 Comparison Value	0=Net, 1=Gross	112	224	<i>reserved</i>	
	205	Setpoint 4 Comparison Value	0=Net, 1=Gross		225	On Error Analogue Output	0=HI, 1=LO
103	206	Setpoint 1 Color	0=No Change, 1=Amber, 2=Red, 3=Green	113	226	Locking code [4]	Digit 3
	207	Setpoint 2 Color	0=No Change, 1=Amber, 2=Red, 3=Green		227		Digit 2
228				Digit 1			
229	Digit 0						
104	208	Setpoint 3 Color	0=No Change, 1=Amber, 2=Red, 3=Green	114	230	Programming Lock (1)	Bit 0 : Lock Set 1
	209	Setpoint 4 Color	0=No Change, 1=Amber, 2=Red, 3=Green				Bit 1 : Lock Set 2
105	210	<i>reserved</i>		115	231	Programming Lock (2)	Bit 2 : Lock Set 3
	211	<i>reserved</i>					Bit 3 : Lock Set 4
106	212	<i>reserved</i>		116	232	Programming Lock (3)	Bit 4 : Lock Input
	213	<i>reserved</i>					Bit 5 : Lock Display
107	214	Analogue Output HI [5]	Digit 4 (if Hysteresis)	117	233	Logic Function IN 1	Bit 6 : Lock Filter
	215		Digit 3 (if Hysteresis)				234
108	216		Digit 2 (if Hysteresis)	235	Logic Function IN 3	Direct Setpoints	
	217		Digit 1			Bit 1 : Lock RS / ETH ports	
109	218		Digit 0	Bit 2 : Lock Logical Functions			
	219	Digit 4 (if Hysteresis)	Bit 3 : Total Lock (except keypad)				
110	220	Analogue Output LO [5]	Digit 3 (if Hysteresis)	Bit 4 : Lock Analogue Output			
	221		Digit 2 (if Hysteresis)	Bit 0 : Lock Brightness-Color-Eco			
111	222		Digit 1	Bit 1 : -			
	223		Digit 0	Bit 2 : Lock TARE key			
				Bit 3 : Lock MAX/ MIN key			

MODBUS – RTU MAP ADDRESSES

Programming Data (Read Only)			
118	236	IP address Ethernet Port	IPAddress [0]
	237		IPAddress [1]
119	238		IPAddress [2]
	239		IPAddress [3]
120	240	Unit Adresse RS232/485 Port	RS Address [0]
	241		RS Address [1]
121	242	Baud Rate RS232/485	0=1200, 1=2400, 2=4800, 3=9600, 4=19200
	243	Protocol RS232/485	0=ASCII, 1=ISO1745, 2=Modbus RTU
122	244	Delay Response RS485	0=No, 1=30ms, 2=60ms, 3=120ms, 4=250ms
	245	<i>reserved</i>	
Dynamic Values (Read Only)			
131	262	Display Value (Long Format)	
	263		
132	264		
	265		
133	266	Input Value (Long Format)	
	267		
134	268		
	269		

135	270	Display Decimal Point	0=99999, 1=9999.9, 2=999.99, 3=99.999, 4=9.9999
	271	Input Decimal Point	0=99999, 1=9999.9, 2=999.99, 3=99.999, 4=9.9999
136	272	Tare Set Value (Long Format)	
	273		
137	274	Tare Value (Long Format)	
	275		
138	276	Tare Value (Long Format)	
	277		
139	278		
	279		
140	280	Max Value (Long Format)	
	281		
141	282		
	283		
142	284	Min Value (Long Format)	
	285		
143	286		
	287		
144	288	Overflow Input Sign (actual or last)	0="+", 1="-"
	289	Overflow Display Sign (actual or last)	0="+", 1="-"
145	290	Overflow Input	0= NO, 1=Yes
	291	Overflow Display	0= NO, 1=Yes

MODBUS – RTU MAP ADDRESSES

146	292	Setpoint 1 Value (Long Format)	
	293		
147	294		
	295		
148	296	Setpoint 2 Value (Long Format)	
	297		
149	298		
	299		
150	300	Setpoint 3 Value (Long Format)	
	301		
151	302		
	303		
152	304	Setpoint 4 Value (Long Format)	
	305		
153	306		
	307		
154	308	<i>reserved</i>	
	309	<i>reserved</i>	
155	310	<i>reserved</i>	
	311	<i>reserved</i>	
156	312	Status Alarm Setpoint 1	
	313	Status Alarm Setpoint 2	
157	314	Status Alarm Setpoint 3	
	315	Status Alarm Setpoint 4	
158	316	Actual Display Color	0 =Amber, 1 =Red, 2 =Green
	317	Actual Display Brightness	0 =HI, 1 =LO
159	318	Sensor Break Error	0 = NO, 1 =Yes
	319	Input Limit Error	0 = NO, 1 =Yes

160	320	installed Options	
	321	<i>reserved</i>	
161	322	Software Version	200
	323	Hardware Ver- sion	0x6D = "m"
Dynamic Values (Write Only)			
1136	2272	Tare Set Value (Long Format)	Not saved in memory
	2273		
	2274		
	2275		
1146	2276	Setpoint 1 Value (Long Format)	Not saved in memory
	2277		
1147	2278		
	2279		
1148	2280	Setpoint 2 Value (Long Format) Cal_Pointer	Not saved in memory
	2281		
1149	2282		
	2283		
1150	2284	Setpoint 3 Value (Long Format)	Not saved in memory
	2285		
1151	2286		
	2287		
1152	2288	Setpoint 4 Value (Long Format)	Not saved in memory
	2289		
1153	2290		
	2291		

ANALOG OUTPUT OPTION by KEYBOARD

Introduction

Two ranges of analog output (0-10 V and 4-20 mA) can be incorporated to the **MICRA-M MAX** by means of an additional card, either the **NMV** card for voltage output or the **NMA** card for current output, which is installed on the meter's main board via plug-in connector M3, both cards, cannot be used simultaneously.

The outputs are opto-isolated with respect to the signal input and the power supply.

The optional board provides a two terminal connector [(+) and (-)] that drives out a signal variation from 0 to 10V or from 4mA to 20mA proportional to a user-defined display range.

This way, the meter is furnished with a signal that can be used to control variables and operates at each moment proportionally to the magnitude of the effect under control.

These signals can also be used to transmit display information to a variety of terminal equipment such as graphic recorders, controllers, remote displays or other devices that accept input data in analog form.

The instrument will detect the type of option that has been installed and will operate in accordance.

The display values producing the full scale output (OUT-HI and OUT-LO) are also introduced via front-panel buttons in the same programming module. The analog output then follows the display variation between the HI and LO programmed points.

The output signal can be set up for reverse action by programming the low display for the high output (OUT-HI) and the high display for the low output (OUT-LO).

In case of 'display overflow', 'sensorbreak' or 'input error', the output signal (V or mA) can be configured to be fixed at a high level 'Hi' or a low level 'Lo'.

INSTALLATION of NMA or NMV option

Lift out the electronics assembly from the case and use a screwdriver to pull on the junctions between the case and the grey-marked area to detach it from the case. The so performed orifice will allow the analog output board connect or be brought out at the rear of the instrument. Install the circuit board so that the lower pin fits into the corresponding main board insertion slot and push down to plug the M3 option connector in the main board M3 location. If the instrument is to be installed in high vibrating environments, it is recommended to solder the card to the main board making use of the copper tracks on both sides of the card pin and around the main board hole on its solder side.

WIRING

Each output card is supplied with an adhesive label that indicates the wiring connections of each option (see fig.). To help identifying each terminal, this label should be placed in the lower side of the meter case, beside the basic functions label.

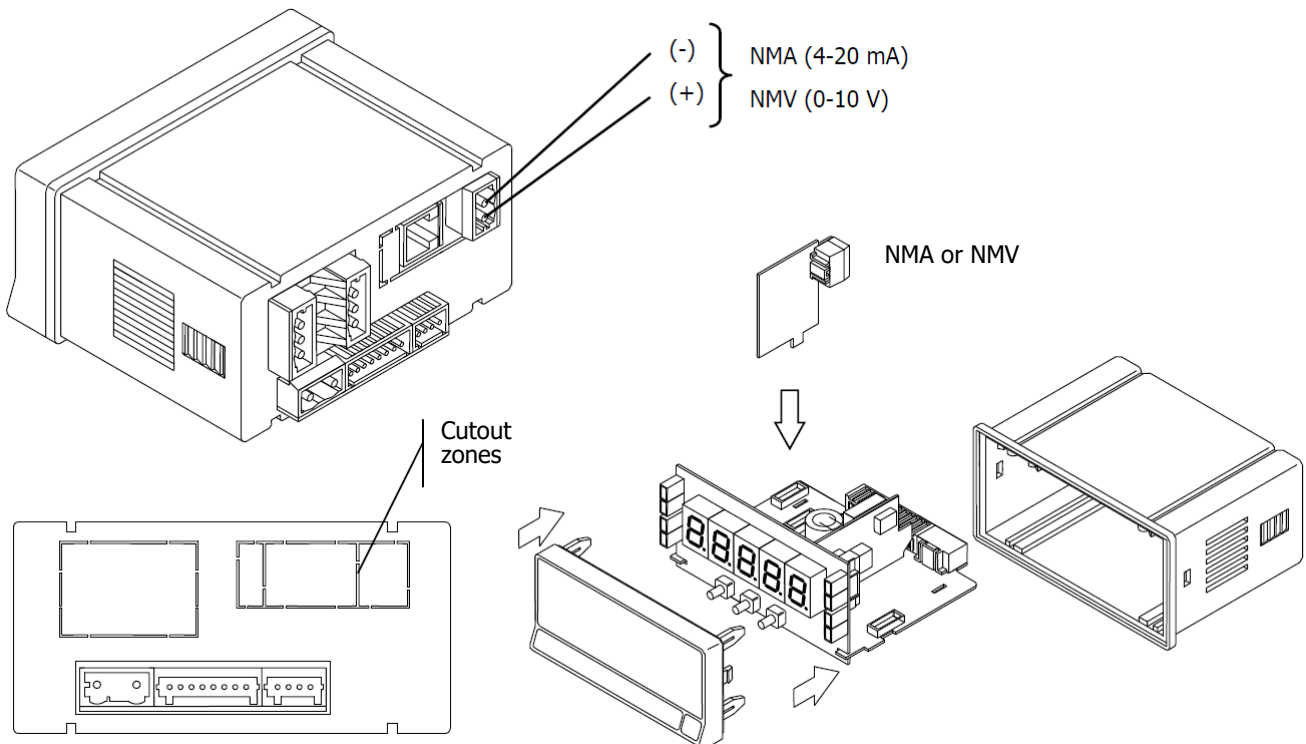

ANALOG OUTPUT OPTIONS

Technical Specifications

CHARACTERISTICS	NMA OUTPUT	NMV OUTPUT
RESOLUTION.....	13 BITS	13 BITS
ACCURACY	0.1% F.S. ±1BIT	0.1% F.E. ±1BIT
RESPONSE TIME.....	10 ms	10 ms
THERMAL DRIFT.....	0.5 µA/°C	0.2 mV/°C
MAX. LOAD.....	≤ 500 Ω	≥ 10 KΩ

Analog Output Menu Diagram

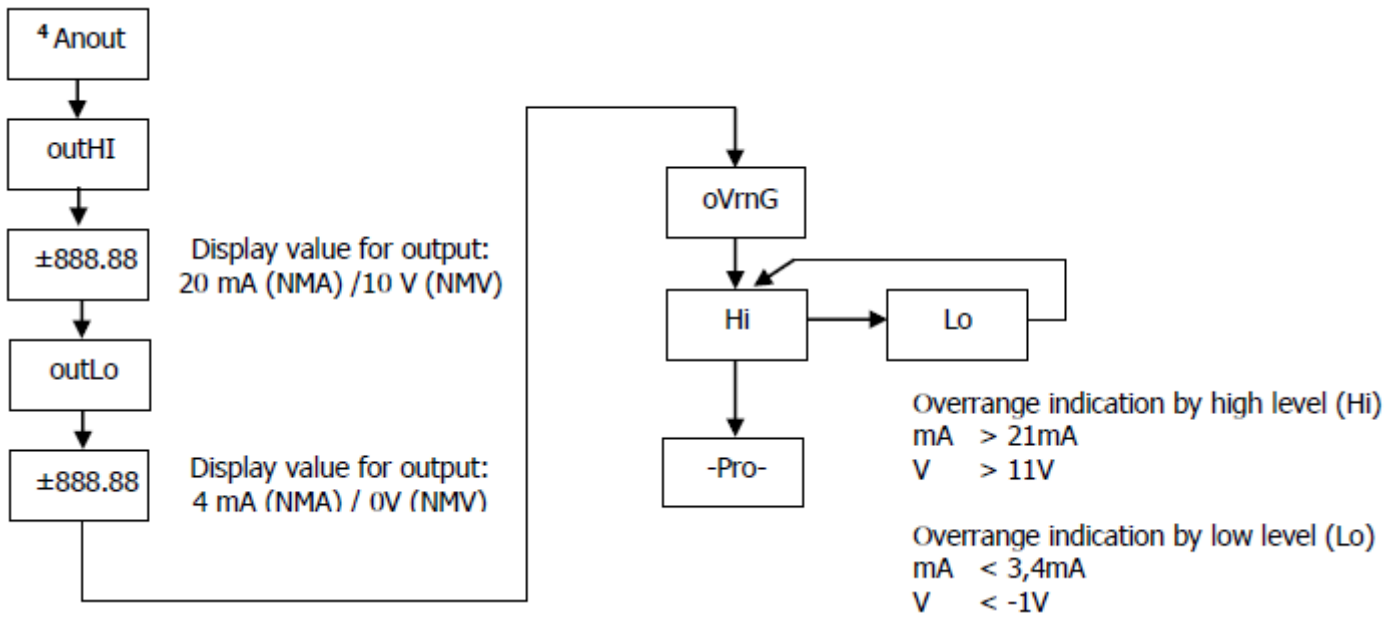

TECHNICAL SPECIFICATIONS

INPUT SIGNAL

Configurationasymmetric differential

Process Input

Voltage **Current**
 Range ±10 V DC ..20 mA DC
 Máx. resolution1 mV1 µA
 Input Impedance1 MΩ15 Ω
 Excitation24 V @ 60 mA, 10/ 5 V @ 60 mA
 Max. Error± (0.1% of the reading +1 digit)

Load Cell Input

Voltage±15 mV ± 30mV ± 150mV
 Máx. resolution1 µV
 Input Impedance100 MΩ
 Excitation10/ 5V @ 60 mA
 Max. Error± (0.1% of the reading +1 digits)

Potentiometer Input

Voltage±10 V DC
 Input Impedance1 MΩ
 Display Resolution0.001%
 Max. error± (0.1% of the reading+1 digit)
 Potentiometer minimum value200Ω

Temperature Input

Cold Junction compensation-10 °C to +60 °C
 Cold Junction±(0.05 °C/ °C +0.1 °C)
 Pt100 sensor excitation< 1 mA DC
 Máx. lead resistance40Ω/wire (balanced)

Input	Range (res. 0.1 °)	Accuracy (res. 0.1%)	Range (res. 1°)	Accuracy (res. 1°)
TC J	-150,0 to +1100,0 °C	0.4% rdg ±0.6 °C	-150 to +1100 °C	0.4% rdg ±1 °C
	-238,0 to +2012,0 °F	0.4% rdg ±1 °F	-238 to +2012 °F	0.4% rdg ±2 °F
TC K	-150,0 to +1200,0 °C	0.4% rdg ±0.6 °C	-150 to +1200 °C	0.4% rdg ±1 °C
	-238,0 to +2192,0 °F	0.4% rdg ±1 °F	-238 to +2192 °F	0.4% rdg ±2 °F
TC T	-200,0 to +400,0 °C	0.4% rdg ±0.6 °C	-200 to +400 °C	0.4% rdg ±1 °C
	-328,0 to +752,0 °F	0.4% rdg ±1 °F	-328 to +752 °F	0.4% rdg ±2 °F
TC N	-150,0 to +1300,0 °C	0.4% rdg ±0.6 °C	-150 to +1300 °C	0.4% rdg ±1 °C
	-238,0 to +2372,0 °F	0.4% rdg ±1 °F	-238 to +2372 °F	0.4% rdg ±2 °F
Pt100	-200,0 to +800,0 °C	0.2% rdg ±0.6 °C	-200 to +800 °C	0.2% rdg ±1 °C
	-328,0 to +1472,0 °F	0.2% rdg ±1 °F	-328 to +1472 °F	0.2% rdg ±2 °F

MÁX input signal applicable

.Process mA.....±22 mA
 .Process V.....±11 V
 .Load Cell
 ±15 mV±16.5 mV
 ±30 mV±33 mV
 ±150 mV.....±165 mV

MÁX. continuous overload inputs V and mV50 V
 MÁX. continuous overload input mA50 mA

DISPLAY

Principal-19999/ 99999, 5 digits tricolor 14 mm
 Decimal pointprogrammable
 LEDs4 for functions and 4 for outputs
 Display update rate
 Process/Load Cell20/s
 Pt10020/s
 Thermocouple10/s
 Input overrange, display-oUEr, oUEr

CONVERSION

TechniqueSigma/ Delta
 Resolution(±15 bit)
 Rate20/s
 Temperature Coefficient100 ppm/ °C
 Warm up time15 minutes

POWER SUPPLY

MICRA-M MAX....85 VAC-265 VAC/100 VDC-300 VDC
 MICRA-M6 MAX22 VAC-53 VAC/10,5VDC-70 VDC
 Consumption7W (max)

FUSES (DIN 41661) Not included
 MICRA-M MAX (230/115V AC)F 0.5 A / 250 V
 MICRA-M6 MAX (24/48V AC)F 2 A / 250 V

OPEN CIRCUIT OR SHORT CIRCUIT ERROR

Pt100, TC, Load Cell (open) " - - - - "

ZERO INPUT ERROR ('InErr'=Yes)

Process indication, Load Cell " - - - - "

Input signal limits ±0.1% FS

FILTERS

Filter P

Cut-off frequencyfrom 4Hz to 0.05Hz
 Slope20 dB/decade

ENVIRONMENTAL

Indoor use

Operating temp.-10°C to 60°C

Storage temperature-25 °C to +85 °C

Relative humidity non condensed<95 % to 40 °C

Máx. altitude2000 m

DIMENSIONS

Dimensions96x48x60 mm

Panel Cutout92x45 mm

Weight135 g

Case materialpolycarbonate s/UL 94 V-0

Sealed front panelIP65